

HF-SETHYC25 & HF-SETHYC25-1

Zubehör/Accessories/Accessoire/Accessori abbinabili



6721903985.aa.RO

[de] Wichtige Hinweise zur Installation/Montage

Die Installation/Montage muss durch eine für die Arbeiten zugelassene Fachkraft unter Beachtung der geltenden Vorschriften erfolgen.

[en] Important notes on installation/assembly

The installation/assembly must be carried out by a qualified contractor, following these instructions and in compliance with the applicable regulations.

[fr] Instructions importantes pour l'installation/le montage

L'installation/le montage doit être effectué(e) par un spécialiste qualifié pour les opérations concernées et dans le respect de la présente notice et des prescriptions applicables.

[bg] Важни указания във връзка с инсталацията/монтажа

Инсталацията/монтажът трябва да се извършва от лицензиран за работите специалист в съответствие с настоящото ръководство и с приложимите разпоредби.

[cs] Důležité pokyny k instalaci/montáži

Instalaci/montáž musí při dodržení pokynů uvedených v tomto návodu a platných předpisů provést odborný pracovník s příslušným oprávněním pro tyto práce.

[da] Vigtige anvisninger til installationen/monteringen

Installationen/monteringen skal foretages af en godkendt installatør under overholdelse af denne vejledning og de gældende forskrifter.

[el] Σημαντικές υποδείξεις για την εγκατάσταση/συναρμολόγηση

Η εγκατάσταση/τοποθέτηση πρέπει να ανατίθεται σε εκπαιδευμένο για τις συγκεκριμένες εργασίες τεχνικό προσωπικό με τήρηση αυτών των οδηγιών καθώς και των σχετικών προδιαγραφών.

[es] Indicaciones importantes para instalación/montaje

La instalación/el montaje debe realizarla personal especializado que esté autorizado para realizar estos trabajos y que tenga en cuenta estas instrucciones y la normativa vigente.

[et] Olulised juhised paigaldamiseks/montaažiks

Paigaldamist/montaaži tohib läbi viia vaid selleks volitusi omav spetsialist, arvestades kehtivaid nõudeid.

[nl-BE] Belangrijke aanwijzingen betreffende de installatie/montage

De installatie/montage moet worden uitgevoerd door een voor de werkzaamheden geautoriseerde installateur rekening houdend met deze handleiding en de geldende voorschriften.

[fi] Tärkeitä asennus- ja kokoonpano-ohjeita

Näihin töihin hyväksytyin ammattiasentajan pitää suorittaa asennus- ja kokoonpanotyöt voimassa olevien määräysten mukaisesti.

[hu] Fontos tudnivalók az installáláshoz/szereléshez

A telepítést/szerelést egy, a munkálatokra felhatalmazott szakembernek kell végeznie, jelen utasítás és az érvényes előírások figyelembevételével.

[it] Avvertenze importanti per l'installazione/il montaggio

L'installazione/il montaggio deve aver luogo ad opera di una ditta specializzata ed autorizzata in osservanza di queste istruzioni e delle direttive vigenti.

[ka] მნიშვნელოვანი მითითებები ინსტალაციისთვის/მონტაჟისთვის

ინსტალაცია/მონტაჟი უნდა განხორციელდეს სამუშაოებისთვის დაშვებული კვალიფიციური პერსონალის მიერ, მოქმედი განაწესის დაცვით.

[lt] Svarbios instaliavimo ir (arba) montavimo nuorodos

Instaliavimo / montavimo darbus, laikydamiės šios instrukcijos reikalavimų ir galiojančių taisyklių, privalo atlikti šioms darbams įgalioti specialistai.

[lv] Svarīgi norādījumi par iekārtas uzstādīšanu / montāžu

Uzstādīšanu/montāžu jāveic atbilstošajiem darbiem sertificētam speciālistam, ievērojot šo instrukciju un spēkā esošos noteikumus.

[nl] Belangrijke aanwijzingen betreffende de installatie/montage

De installatie/montage moet door een erkend installateur volgens de geldende voorschriften worden uitgevoerd.

[no] Viktig informasjon om installasjon/montering

Installasjonen/monteringen skal gjennomføres av autoriserte installatører, og installasjonsanvisningen samt gjeldende forskrifter skal følges.

[pl] Ważne wskazówki dotyczące instalacji/montażu

Instalację/montaż powinien wykonać specjalista uprawniony do tego typu prac z uwzględnieniem informacji podanych w niniejszej instrukcji oraz aktualnie obowiązujących przepisów.

[pt] Indicações importantes relativas à instalação/montagem

A instalação/montagem deve ser efectuada por um técnico autorizado para os trabalhos, respeitando este manual e as prescrições válidas.

[ro] Indicații importante privind instalarea/montajul

Instalarea/montajul trebuie realizate de către un specialist autorizat pentru lucrările respective, respectându-se prezentele instrucțiuni și prescripțiile valabile.

[ru] Важные указания по подключению/монтажу

Подключение/монтаж должны выполнять только специалисты, имеющие допуск к выполнению таких работ, при соблюдении требований этой инструкции и действующих норм и правил.

[sk] Dôležité pokyny týkajúce sa inštalácie/montáže

Inštaláciu/montáž musí vykonať odborný personál, ktorý má oprávnenie pre výkon týchto prác, pričom musí dodržiavať pokyny uvedené v tomto návode a platné predpisy.

[sl] Pomembni napotki za namestitvev/montažo

Inštalacija/montažo lahko izvede samo pooblaščen strokovnjak ob upoštevanju teh navodil in veljavnih predpisov.

[sr] Važna uputstva za ugradnju i montažu

Ovu instalaciju/montažu moraju da obave stručna lica koja su ovlašćena za obavljanje takvih radova u skladu sa ovim uputstvom i važećim propisima.

[sv] Viktiga anvisningar för installation/montering

Installationen/monteringen måste utföras av en behörig och tekniskt utbildad person enligt denna anvisning samt gällande föreskrifter.

[tr] Kurulum/Montaj ile ilgili önemli uyarılar

Kurulum/montaj, bu çalışmalarını yapmasına müsaade edilen uzman kişiler tarafından işbu kılavuz ve geçerli yönetmelikler dikkate alınarak yapılmalıdır.

[uk] Важливі вказівки щодо установки/монтажу

Встановлення/монтаж повинні виконувати фахівці, що допущені до виконання таких робіт, із дотриманням цієї інструкції та діючих приписів.

[zh] 安装方面的重要提示

安装和组装工作必须由经过许可的专业人员进行，同时必须遵守本说明书和现行法规的相关要求

[ar] ملاحظات هامة للتركيب/التجميع

يجب أن يتم التركيب/التجميع من قبل متخصص مصرح له بالعمل، مع مراعاة اللوائح السارية.

[fa] تذکرات مهم درباره نصب/مونتاژ

نصب/مونتاژ باید توسط فردی حرفه ای که مجاز به انجام این کار است، و همچنین با توجه کامل به مقررات مربوطه انجام شود.

Inhaltsverzeichnis Table of contents	Table de matieres Indice	Inhoud Indice
ADAPTOR SET BZ	7736606193	5
BCS36	7736606191	6
HF-HY-B25	8732933184	7
HF-HY-BY25	8732932713	8
HF-HY-LR25	8732933069	9
HF-SETHYC25	8732929705	10
HF-SETHYC25-1	8732951475	11

Ersatzteilliste
 Spare parts list
 Lista parti di ricambio
 Liste des pièces de rechange

ADAPTOR SET BZ - 7736606193

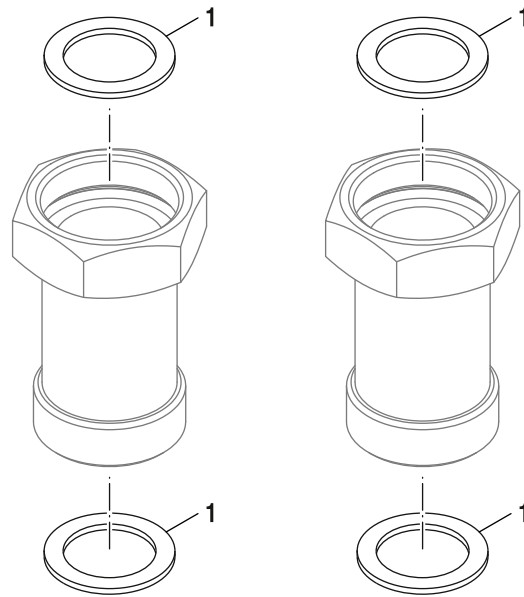

6721904583.aa.RO

	Bestell-Nr.	Bezeichnung	Description	Descrizioni	Dénomination
1	6 302 024 7	Dichtung D24x30,5x2mm (5x) everp	Gasket D24x30,5x2mm (5x)	Guarnizione D24x30,5x2mm, (5 pz.)	LOT DE 5 JOINTS DIAM 24x30,5x2MM

Ersatzteilliste
 Spare parts list
 Lista parti di ricambio
 Liste des pièces de rechange

BCS36 - 7736606191

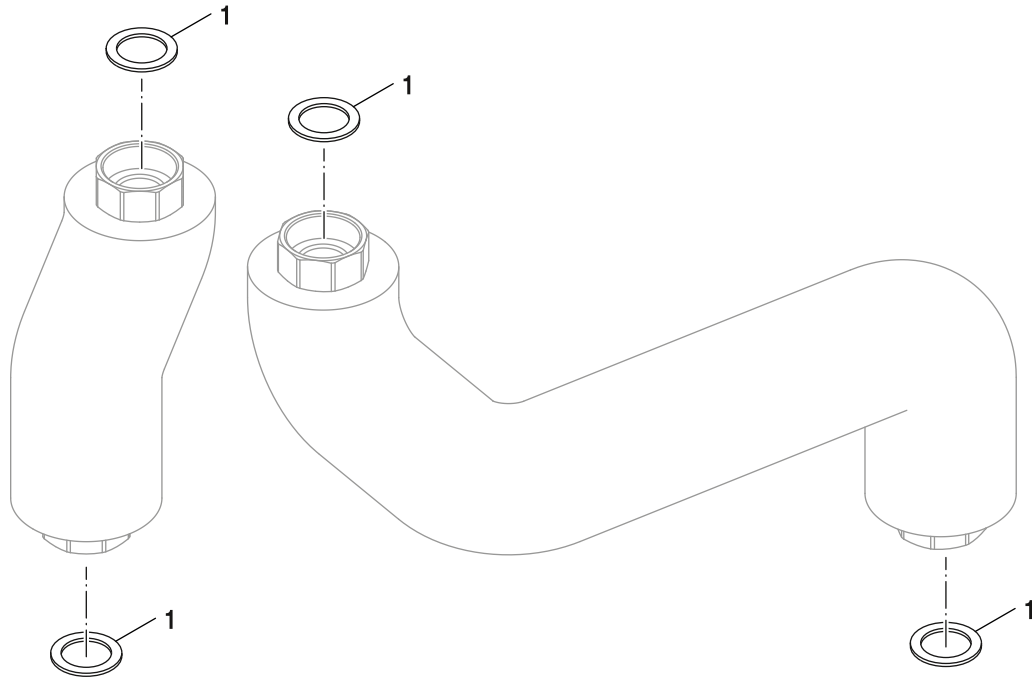

6721904582.aa.RO

	Bestell-Nr.	Bezeichnung	Description	Descrizioni	Dénomination
1	6 302 024 7	Dichtung D24x30,5x2mm (5x) everp	Gasket D24x30,5x2mm (5x)	Guarnizione D24x30,5x2mm, (5 pz.)	LOT DE 5 JOINTS DIAM 24x30,5x2MM

Ersatzteilliste
 Spare parts list
 Lista parti di ricambio
 Liste des pièces de rechange

HF-HY-B25 - 8732933184

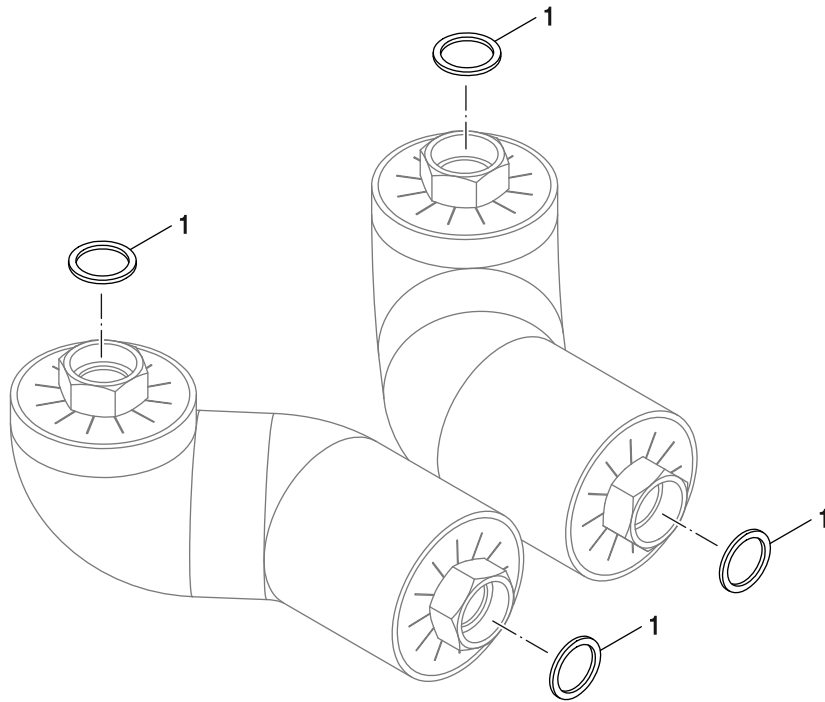

6721904428.aa.RO

	Bestell-Nr.	Bezeichnung	Description	Descrizioni	Dénomination
1	8 718 585 269	Dichtung D24x30,5x2 AFM34 (1x) everp	Seal D24x30,5x2 AFM34 (1x) packed	Guarnizione D24x30,5x2 AFM34 (1x)	Joint D24x30,5x2 AFM34 (1x)

Ersatzteilliste
 Spare parts list
 Lista parti di ricambio
 Liste des pièces de rechange

HF-HY-BY25 - 8732932713

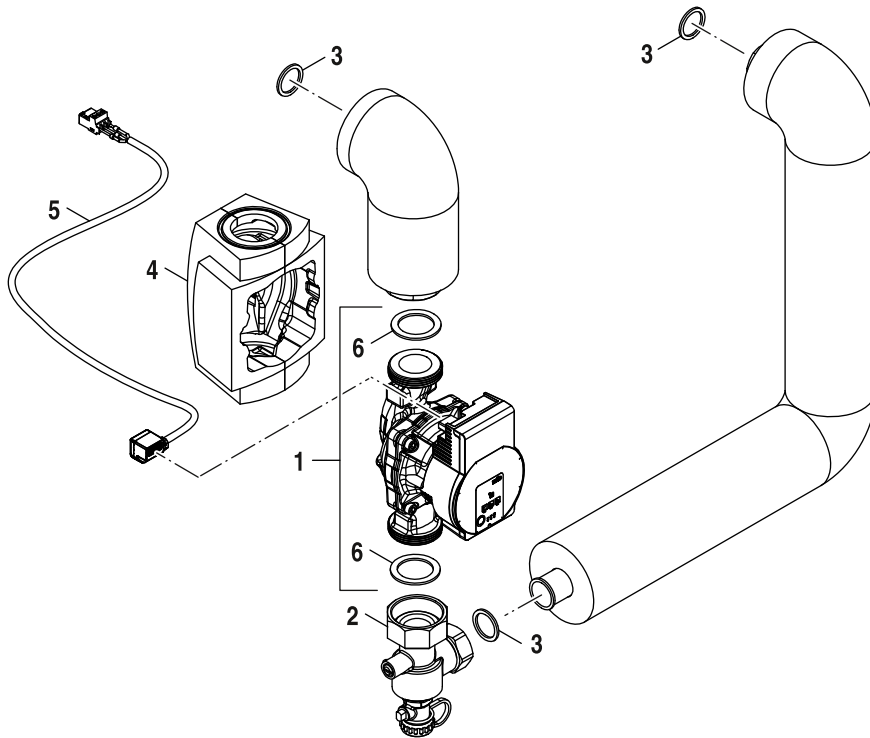

6721903792.ab.RO

	Bestell-Nr.	Bezeichnung	Description	Descrizioni	Dénomination
1	7 736 603 978	Pumpe Para 25-180/6-43/ SC 6H everp	Pump Para 25-180/6-43/SC 6Hsp	Pompa Para 25-180/6-43/ SC 6H	Pompe Para 25-180/6-43/ SC 6H
2	5 681 140	Rückschlagventil Eckform G1"-1 1/2"	Angle non-return valve G1"-1 1/2"	Valvola di non ritorno G1"-1 1/2"	Clapet anti-retour cpl. pour ballon LT
3	8 718 585 269	Dichtung D24x30,5x2 AFM34 (1x) everp	Seal D24x30,5x2 AFM34 (1x) packed	Guarnizione D24x30,5x2 AFM34 (1x)	Joint D24x30,5x2 AFM34 (1x)
4	7 736 603 981	Isolierschalen Pumpe Para 130/180 everp	Insulation pump Para 130/180 sp	Pompa per gusci isolanti Para 130/180	Pompe à coque isolante Para 130/180
5	7 736 603 972	Kabel PARA Stecker grau 3.0m everp	Cable Para Connector grey 3.0m sp	Cavo Para spina grey 3.0m	Câble Para connecteur grey 3.0m
6	6 301 012 3	Dichtung D32x44x2 EPDM (5x) everp	Sealing ring D32x44x2mm (5x) EPDM	Guarnizione D32x44x2mm EPDM	Joint d'étanchéité D32x44x2mm EPDM

Ersatzteilliste
 Spare parts list
 Lista parti di ricambio
 Liste des pièces de rechange

HF-HY-LR25 - 8732933069

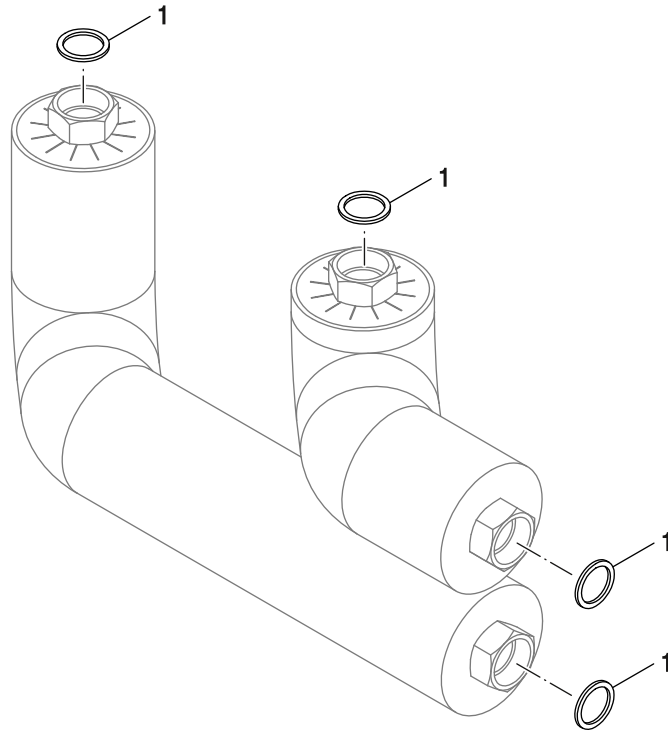

6721904429.aa.RO

	Bestell-Nr.	Bezeichnung	Description	Descrizioni	Dénomination
1	8 718 585 269	Dichtung D24x30,5x2 AFM34 (1x) everp	Seal D24x30,5x2 AFM34 (1x) packed	Guarnizione D24x30,5x2 AFM34 (1x)	Joint D24x30,5x2 AFM34 (1x)

HF-SETHYC25 - 8732929705

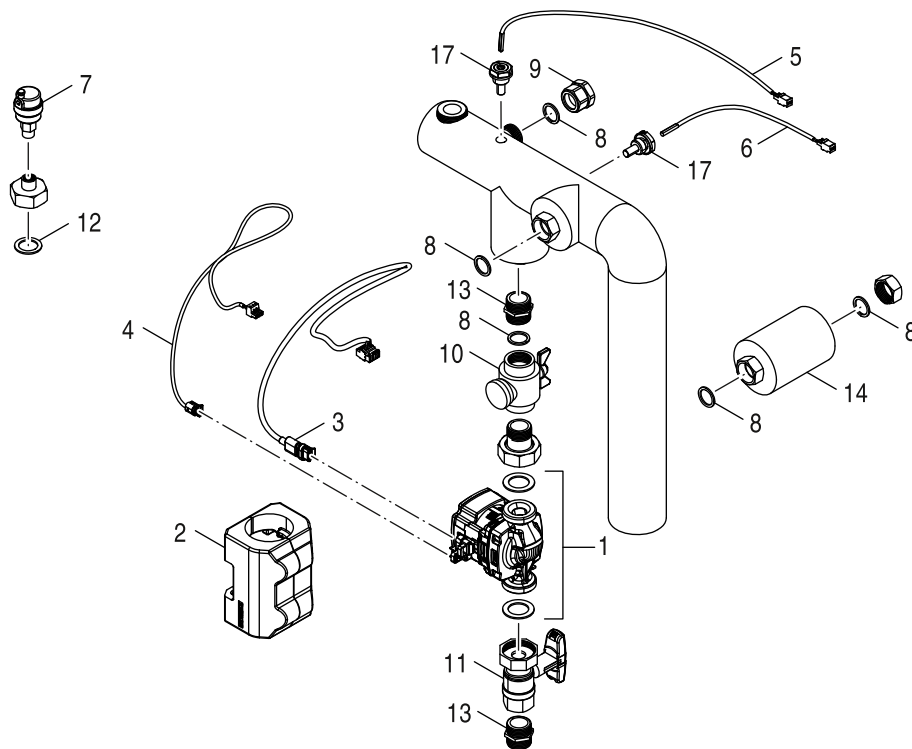

6721903688.ab.RO

	Bestell-Nr.	Bezeichnung	Description	Descrizioni	Dénomination
1	8 738 806 948	Pumpe UPM3 25-75-130 everp	Pump UPM3 25-75-130 everp	Pompa UPM3 25-70-130	Pompe UPM3 25-75-130
2	8 738 806 949	Isolierung UPM3 everp	Insulation pump UPM3 everp	Isolamento UPM3	Isolation UPM3
3	8 732 931 489	Leitung UPM3 Superseal-Stecker 1300 ever	Cable UPM3 Superseal-Conn.1300 Spare Pa	Gestione UPM3	La gestion UPM3
4	8 732 931 490	Verbindungsleitung PWM UPM3 1300 everp	Cable PWM UPM3 1300 Spare Part	Linea di collegamento PWM UPM3	Ligne de connexion PWM UPM3
5	8 732 931 491	Fühler Temp RD 9,7 10K 1000 everp	Sensor RD 9,7 10K 1000 Spare Part	Sensore RD9,7 1000	Capteur RD 9,7 10k 1000
6	8 732 931 492	Fühler Temp RD 9,7 10K 1200 everp	Sensor RD 9,7 10K 1200 Spare Part	Sensore RD9,7 1200	Capteur RD 9,7 10k 1200
7	8 718 585 257	Entlüfter Autom m. Absperrvent 3/8 everp	Air_vent automatic purging system 3/8"	Valvola di sfiato 3/8"	Pot de ventilateur 3/8"
8	6 302 024 7	Dichtung D24x30,5x2mm (5x) everp	Gasket D24x30,5x2mm (5x)	Guarnizione D24x30,5x2mm, (5 pz.)	LOT DE 5 JOINTS DIAM 24x30,5x2MM
9	8 718 585 383	Anschlussstück kpl G1/DN27 everp	Pipe connection part G1/DN27 pckd	Collegamento	Raccordement G1/DN27
10	8 738 807 530	Ventil Filterball 1" DN25 everp	Valve filterball 1" DN25 sp	Valvola 1" DN25 everp	Soupape 1" DN25 everp
11	8 738 807 529	Pumpenkugelhahn G1"x1 1/2" everp	Pump ball valve G1"x1 1 1/2" sp	Circolatore Rubinetto a sfera G1"x1 1/2"	Pompe Robinet à boisseau sphérique
12	8 718 584 801	Dichtung D27x38x2 DVGW-zugelassen everp	Seal D27x38x2 DVGW packed	Guarnizione 27x38x2mm C4400 Klinger SIL	Joint D27x38x2mm C4400 Klinger SIL
13	8 738 807 531	Doppelnippel G1 everp	Nipple with G1 thread sp	Nipplo doppio G1 everp	Raccord double G1 everp
14	8 738 807 533	Rohr BHS Vorlaufstück everp	Pipe BHS flow sp	Tubo BHS	Tube BHS
17	8 738 807 534	Tauchhülse G3/8 6mm everp	Immersion sleeve G3/8 6mm sp	Pozzetto ad immersione G3/8 6mm everp	Support de sonde G3/8 6mm everp

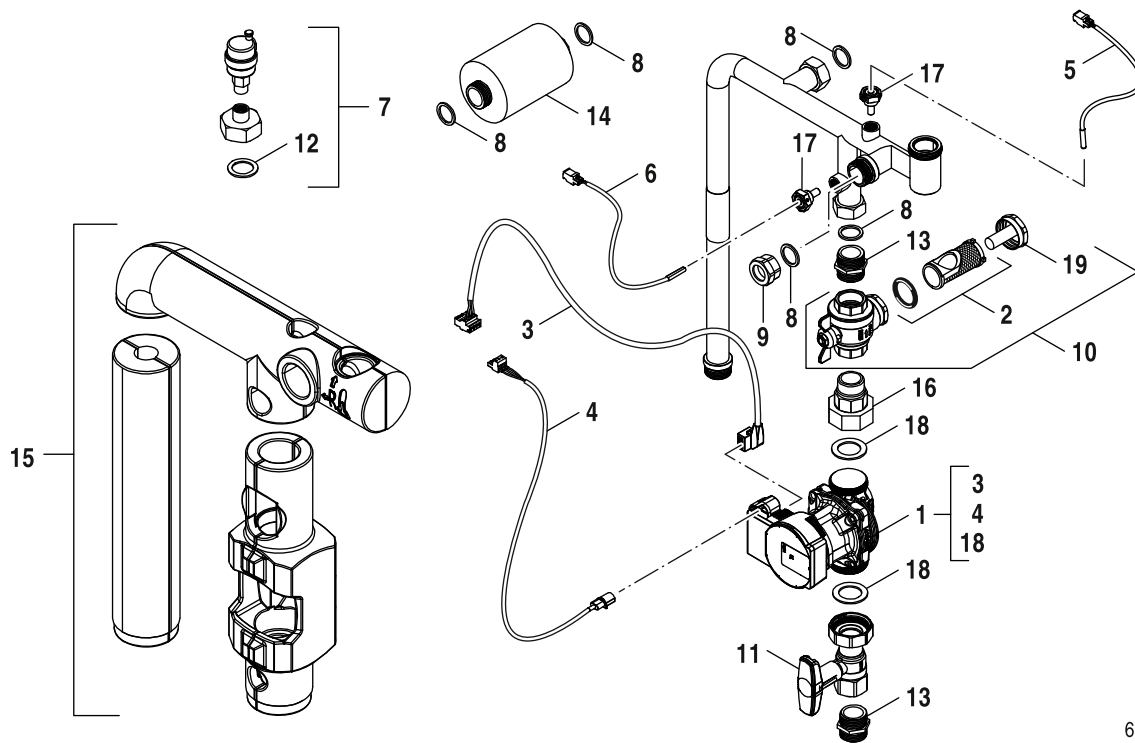

6721904441.aa.RO

	Bestell-Nr.	Bezeichnung	Description	Descrizioni	Dénomination
1	8 738 808 044	Pumpe Wilo Para8-LIN CL3	Pump Wilo Para8-LIN CL3	Circolatore Wilo Para8-LIN CL3	Pompe Wilo Para8-LIN CL3
2	8 733 702 122	Wassersieb DN25	Water strainer DN25	Filtro acqua DN25	filtre eau DN25
3	8 738 808 047	Netzleitung 1300mm	Power cable 1300mm	Cavo di alimentazione 1300mm	Câble d'alimentation 1300mm
4	8 738 808 048	Verbindungsleitung LIN-Bus 1300mm	Connecting cable LIN-Bus 1300mm	Cavo di collegamento LIN-Bus 1300mm	Câble de connexion LIN-Bus 1300mm
5	8 732 931 491	Fühler Temp RD 9,7 10K 1000 everp	Sensor RD 9,7 10K 1000 Spare Part	Sensore RD9,7 1000	Capteur RD 9,7 10k 1000
6	8 732 931 492	Fühler Temp RD 9,7 10K 1200 everp	Sensor RD 9,7 10K 1200 Spare Part	Sensore RD9,7 1200	Capteur RD 9,7 10k 1200
7	8 738 808 050	Entlüfter Set	Air vent set	Disareatore set	Purgeur set
8	6 302 024 7	Dichtung D24x30,5x2mm (5x) everp	Gasket D24x30,5x2mm (5x)	Guarnizione D24x30,5x2mm, (5 pz.)	LOT DE 5 JOINTS DIAM 24x30,5x2MM
9	8 718 585 383	Anschlusssteil kpl G1/DN27 everp	Pipe connection part G1/DN27 pckd	Collegamento	Raccordement G1/DN27
10	8 738 807 530	Ventil Filterball 1" DN25 everp	Valve filterball 1" DN25 sp	Valvola 1" DN25 everp	Soupape 1" DN25 everp
11	8 738 807 529	Pumpenkugelhahn G1"x1 1/2" everp	Pump ball valve G1"x1 1/2" sp	Circolatore Rubinetto a sfera G1"x1 1/2"	Pompe Robinet à boisseau sphérique
12	8 718 584 801	Dichtung D27x38x2 DVGW-zugelassen everp	Seal D27x38x2 DVGW packed	Guarnizione 27x38x2mm C4400 Klinger SIL	Joint D27x38x2mm C4400 Klinger SIL
13	8 738 807 531	Doppelnippel G1 everp	Nipple with G1 thread sp	Nipplo doppio G1 everp	Raccord double G1 everp
14	8 738 807 533	Rohr BHS Vorlaufstück everp	Pipe BHS flow sp	Tubo BHS	Tube BHS
15	8 738 808 043	Isolierung EPP kompl	Insulation EPP compl	Isolamento EPP compl	Isolation EPP compl
16	8 738 808 049	Verschraubung G1 1/2" - G1"	Screw fitting G1 1/2" - G1"	Connessioni giuntate G1 1/2" - G1"	Raccord à vis G1 1/2" - G1"
17	8 738 808 046	Tauchhülse G3/8"	Thermopocket G3/8"	Pozzetto per sensore G3/8"	Support de sonde G3/8"
18	8 718 660 766 0	Dichtungs-Set D32x44x2 AFM34 (5x) everp	Seal Set D32x44x2mm AFM34 (5 pc)	Set guarnizioni D32x44x2 AFM34 (5 pz.)	Kit d'étanchéité D32x44x2 AFM34 (5 pces)
19	8 738 212 827	Filter Ball Kappe mit Magnet DN25	Filter ball cap with magnet DN25	Tappo a sfera del filtro con magnet 25	Filter ball cap with magnet DN25

Bosch Thermotechnik GmbH
Sophienstr. 30-32
D-35576 Wetzlar / Germany