



## PrimAX... RED

### Quick Guide



### DE Konformitäts-Erklärung

Wir Biral AG erklären in alleiniger Verantwortung, dass die Produkte **PrimAX** auf die sich diese Erklärung bezieht, mit folgenden Richtlinien des Rates zur Angleichung der Rechtsvorschriften der EU-Mitgliedstaaten übereinstimmen.

### IT Dichiarazione di conformità

Noi Biral AG dichiariamo sotto la nostra esclusiva responsabilità che i prodotti **PrimAX** ai quali questa dichiarazione si riferisce, sono conformi alle direttive del Consiglio, riguardo l'adeguamento delle prescrizioni di legge degli stati membri CE.

### NL Verklaring van conformiteit

Wij verklaren onder uitsluitende verantwoordelijkheid van Biral AG, dat de **PrimAX**-producten waarop deze verklaring betrekking heeft, overeenstemmen met de volgende richtlijnen van de Raad betreffende de onderlinge aanpassing van de wetgevingen van de lidstaten van de EU.

### RO Declarația de conformitate

Noi, Biral AG, declarăm pe proprie răspundere că produsele **PrimAX** la care se referă această declarație corespund cu următoarele Directive ale Consiliului pentru armonizarea prevederilor legale ale statelor membre EU.

### GR Δήλωση Συμμόρφωσης

Εμείς, η BIRAL AG δηλώνουμε με αποκλειστική ευθύνη μας ότι το προϊόν μας **PrimAX** με το οποίο σχετίζεται η δήλωση αυτή, είναι σύμφωνο με τις οδηγίες του Συμβουλίου για την προσέγγιση των νομοθεσιών των κρατών μελών της ΕΕ.

### FR Déclaration de conformité

Nous Biral AG déclarons sous notre seule responsabilité que les produits **PrimAX** auxquels se réfère cette déclaration sont conformes aux Directives du Conseil des législations des États membres de l'UE.

### EN Declaration of conformity

At Biral AG we declare under our sole responsibility that the **PrimAX** products, to which this declaration refers, are in accordance with the following guidelines of the council for the approximation of laws of the EU member states.

### ES Declaración de conformidad

Nosotros Biral AG declaramos bajo nuestra única responsabilidad que los productos **PrimAX** a los cuales se refiere esta declaración son conformes con las Directivas del Consejo relativas a la aproximación de las legislaciones de los Estados Miembros de la EU sobre.

### PL Deklaracja zgodności

My – firma Biral AG – oświadczamy na własną odpowiedzialność, że produkty **PrimAX** do których odnosi się niniejsza deklaracja, są zgodne z dyrektywami Rady w sprawie zbliżenia ustawodawstw Państw Członkowskich UE.

### РУС Декларация соответствия

Мы, компания Biral AG, принимая на себя полную ответственность, заявляем, что продукция **PrimAX** к которой относится данное заявление, удовлетворяет требованиям Директивы Совета ЕС по согласованию правового регулирования государств-членов ЕС относительно.





Low Voltage Directive (2014/35/EC).  
Standard used: EN 60335-1:2012/A11:2014/A13:2017  
and EN 60335-2-51:2003/A1:2008/A2:2012

EMC Directive (2014/30/EC).  
Standards used: EN 55014-1:2017 and EN 55014-  
2:2015

Ecodesign Directive (2009/125/EC).  
Circulator Pumps: Commission Regulation No 641/2009  
and 622/2012.  
Standards used: EN 16297-1: 2012 and EN 16297-2:  
2012 and EN 16297-3:2012

Münsingen, 31.10.2020

Roger Steuri  
Head of Product Development/Management

Person authorised to compile the technical file and  
to sign the EC Declaration of Conformity

**Biral AG**  
Südstrasse 10  
CH-3110 Münsingen  
T +41 31 720 90 00  
F +41 31 720 90 10  
info@biral.ch  
www.biral.ch



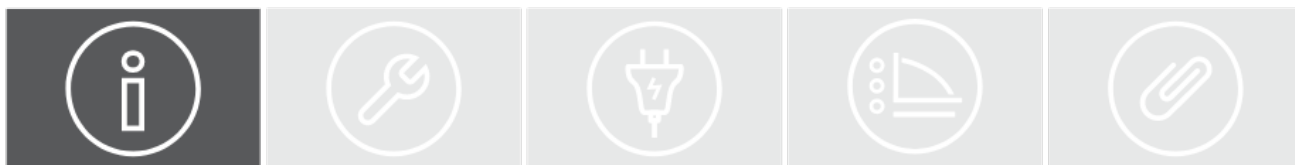

#### DE Sicherheitshinweise

Der elektrische Anschluss muss von einem Fachmann ausgeführt werden. Die Vorschriften des örtlichen Energieversorgungsunternehmens (EVU) sind zu beachten.

#### FR Consignes de sécurité

Le raccordement électrique doit être exécuté par un électricien en accord avec le fournisseur local d'énergie.

#### IT Avvertenze di sicurezza

L'allacciamento elettrico deve essere eseguito da un tecnico specialista in conformità a quanto previsto dalle aziende di approvvigionamento di energia del posto.

#### EN Safety information

The electrical connection must be provided by a technician in coordination with the local utility company.

#### NL Veiligheidsinstructies

De elektrische aansluiting moet door een gekwalificeerd elektricien uitgevoerd worden. De aansluiting moet conform de NEN 1010 en de plaatselijke voorschriften geschieden.

#### ES Información de seguridad

La conexión eléctrica debe ser efectuada por un electricista y de acuerdo con las disposiciones de las empresas de suministro de energía locales.

#### RO Siguranță

Răcordarea electrică trebuie efectuată de către un specialist. Trebuie respectate prevederile companiei locale de furnizare a energiei electrice (EVU).

#### PL Bezpieczeństwo

Połączenie elektryczne musi być wykonane przez uprawnionego elektryka. Należy przestrzegać przepisów miejscowego zakładu energetycznego.

#### GR Οδηγίες Ασφάλειας

Η ηλεκτρική σύνδεση πρέπει να παρέχεται από έναν τεχνικό σε συντονισμό με την τοπική εταιρεία κοινής ωφελείας.

#### РУС безопасности

Электрическое соединение должно выполняться техническим специалистом при согласовании с местным энергетическим предприятием.





Abmessungen Dimensions Dimensioni Dimensions Afmetingen Dimension Dimensiuni Wymiary Размеры Διαστάσεις	Typenreihe Série Gamma Series Serie Seriea Seria Typozereg Типовой ряд Σειρά								
<b>PrimAX</b>									
	<b>15-3 130 PN 10</b>	<b>15-4 130 PN 10</b>	<b>15-6 130 PN 10</b>	<b>15-8 130 PN 10</b>					
<b>DN</b>	15	15	15	15					
<b>L</b>	130	130	130	130					
<b>L1</b>	105	105	105	105					
<b>G</b>	1"	1"	1"	1"					
<b>kg</b>	1.7	1.7	1.7	1.7					

	<b>25-3 130 PN 10</b>	<b>25-4 130 PN 10</b>	<b>25-6 130 PN 10</b>	<b>25-8 130 PN 10</b>		<b>25-3 180 PN 10</b>	<b>25-4 180 PN 10</b>	<b>25-6 180 PN10</b>	<b>25-8 180 PN 10</b>
<b>DN</b>	25	25	25	25		25	25	25	25
<b>L</b>	130	130	130	130		180	180	180	180
<b>L1</b>	105	105	105	105		140	140	140	140
<b>G</b>	1 1/2"	1 1/2"	1 1/2"	1 1/2"		2"	2"	2"	2"
<b>kg</b>	1.8	1.8	1.8	1.8		1.9	1.9	1.9	1.9

	<b>32-3 170 PN 10</b>	<b>32-4 170 PN 10</b>	<b>32-6 170 PN 10</b>	<b>32-8 170 PN 10</b>		<b>32-3 180 PN 10</b>	<b>32-4 180 PN 10</b>	<b>32-6 180 PN 10</b>	<b>32-8 180 PN 10</b>
<b>DN</b>	32	32	32	32		32	32	32	32
<b>L</b>	170	170	170	170		180	180	180	180
<b>L1</b>	140	140	140	140		140	140	140	140
<b>G</b>	2"	2"	2"	2"		2"	2"	2"	2"
<b>kg</b>	2.1	2.1	2.1	2.1		2.1	2.1	2.1	2.1



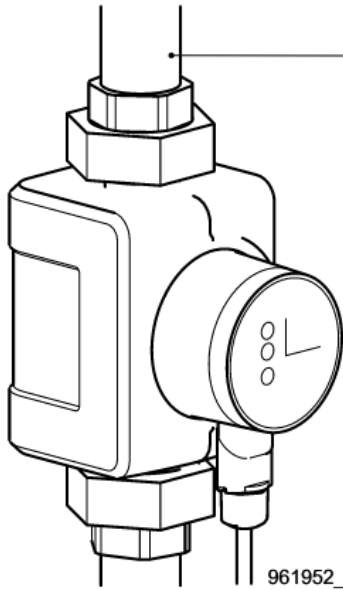

961952\_00



min. +2°C  
max. +110°C

max. 10 bar

min. +0°C  
max. +40°C

IPX4D

50/60 Hz

1~230V

< 43 dB(A)

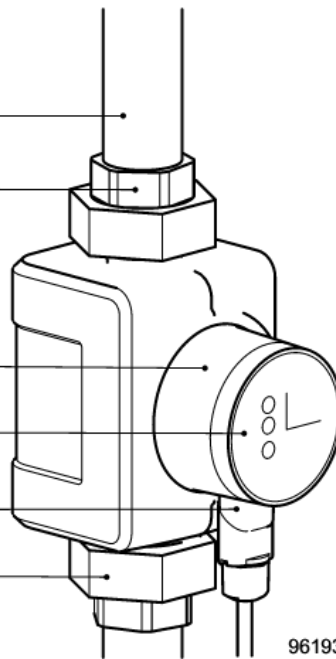

961936\_00



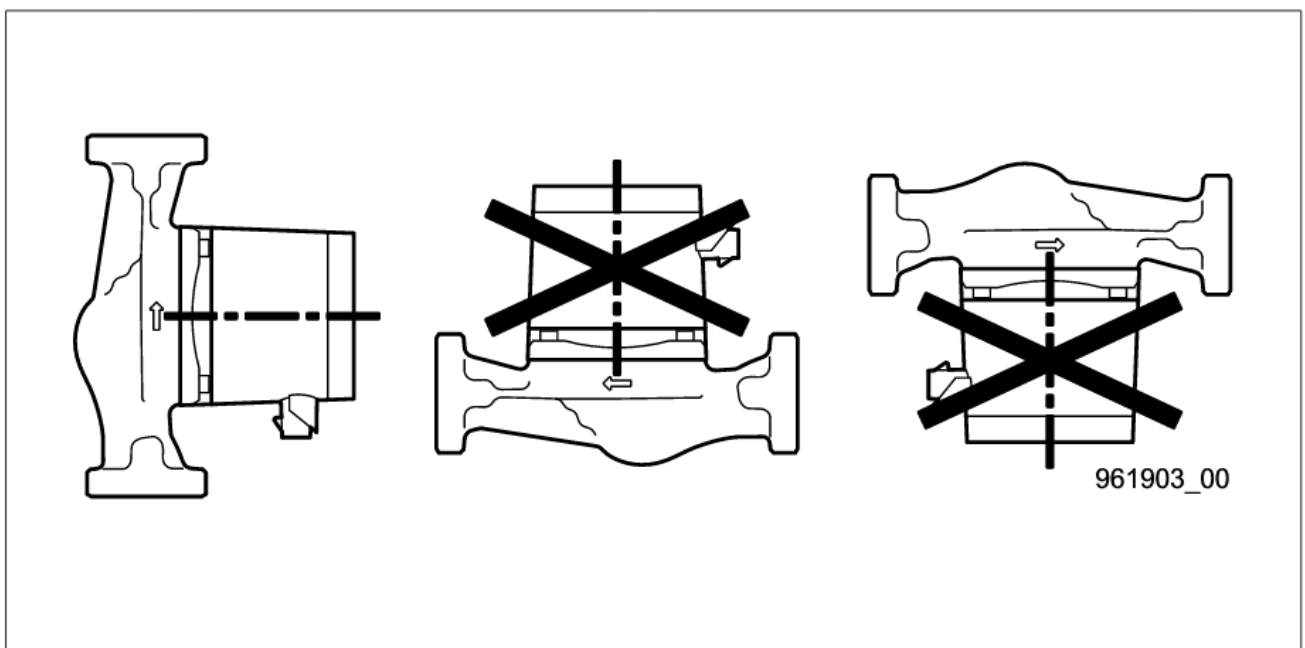
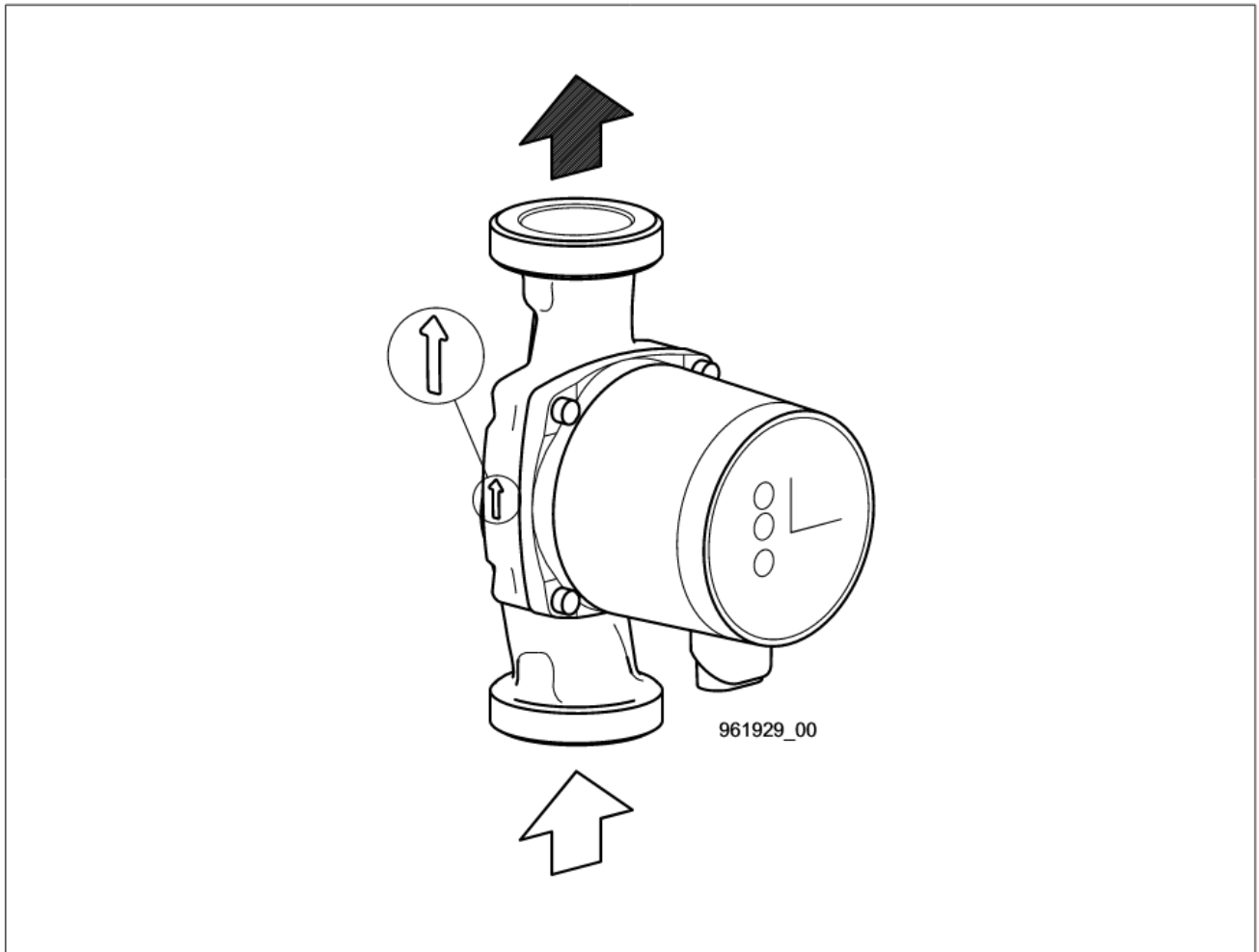



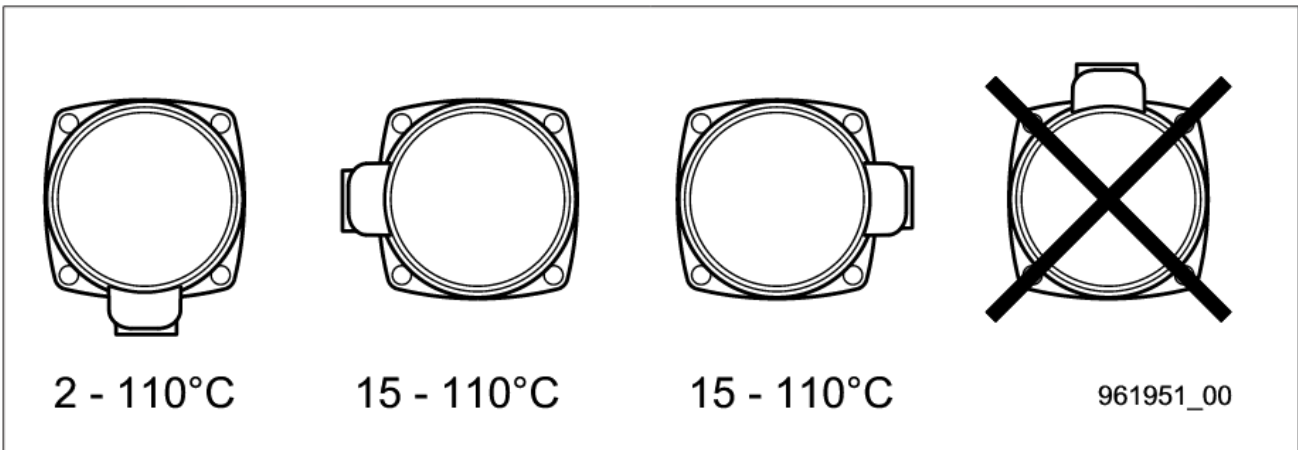
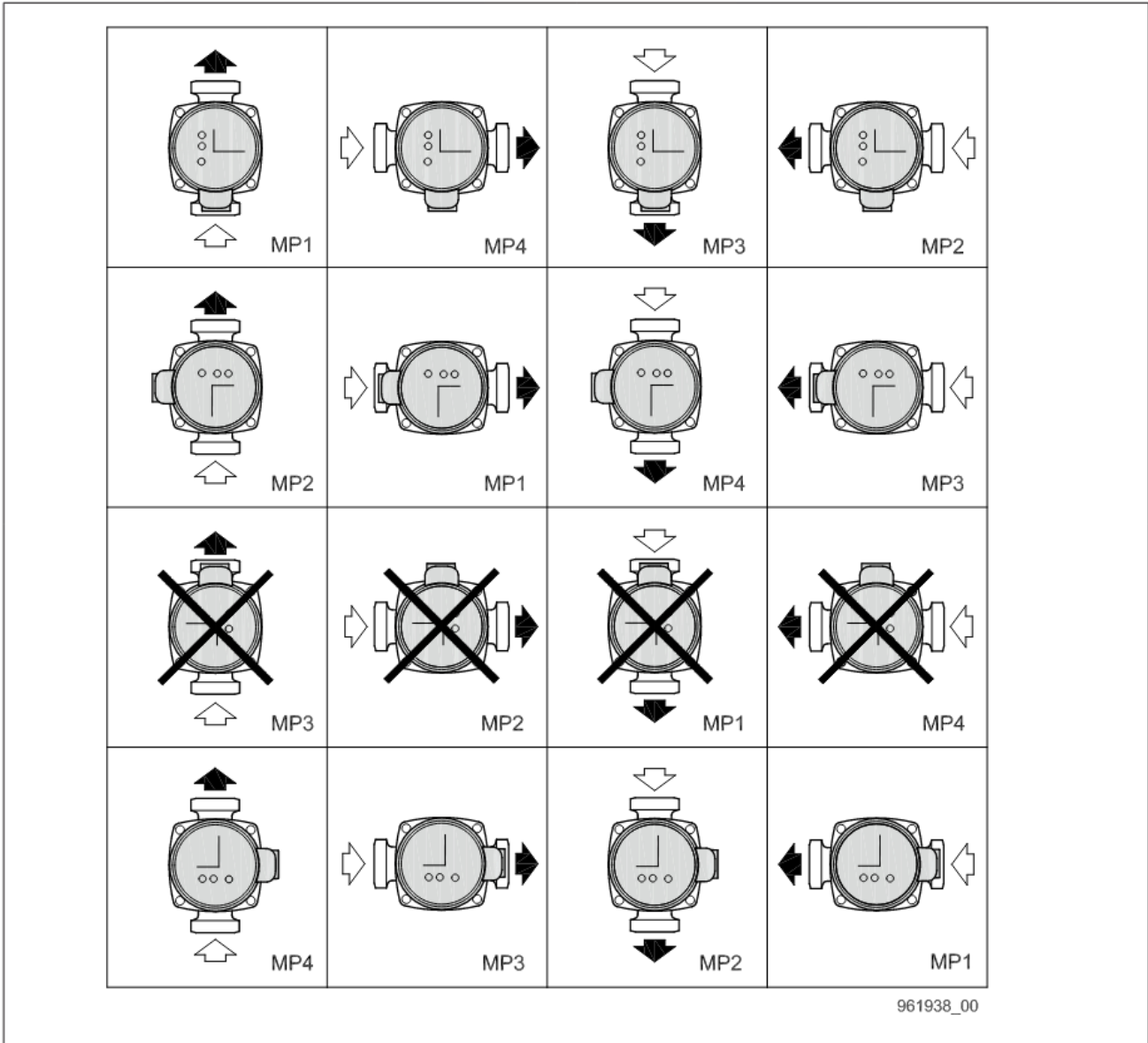



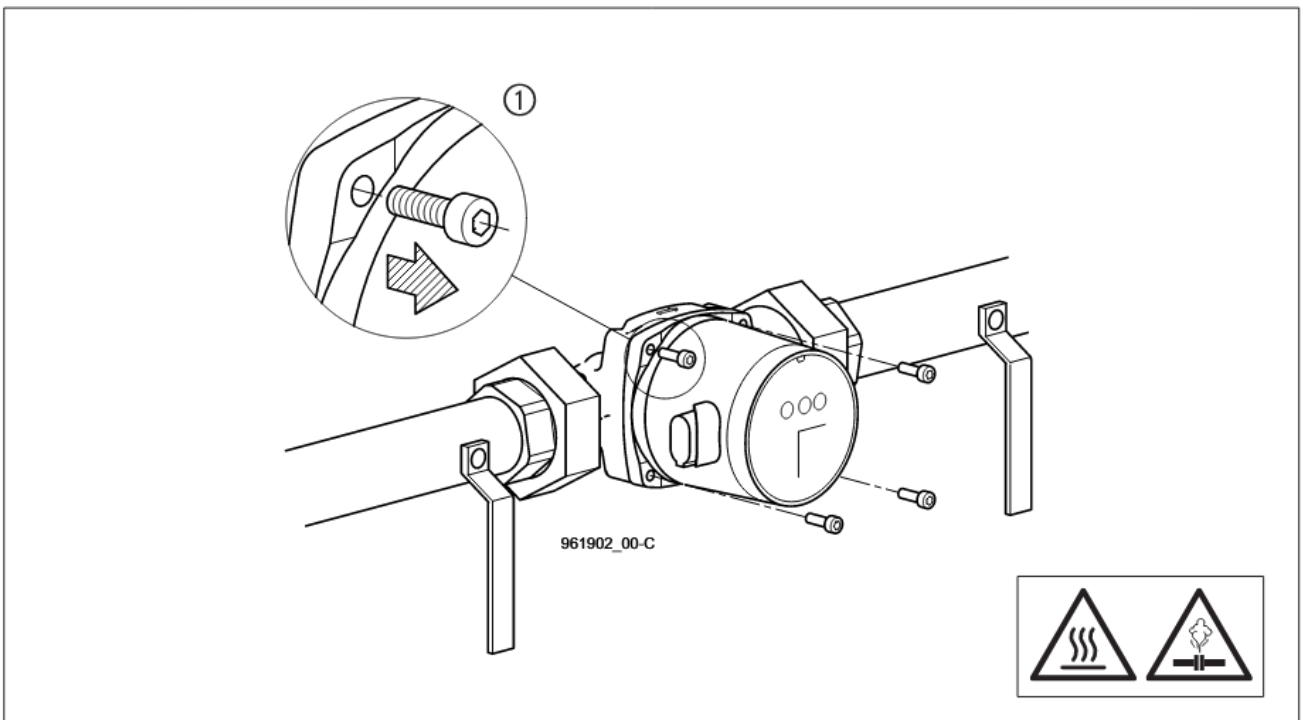
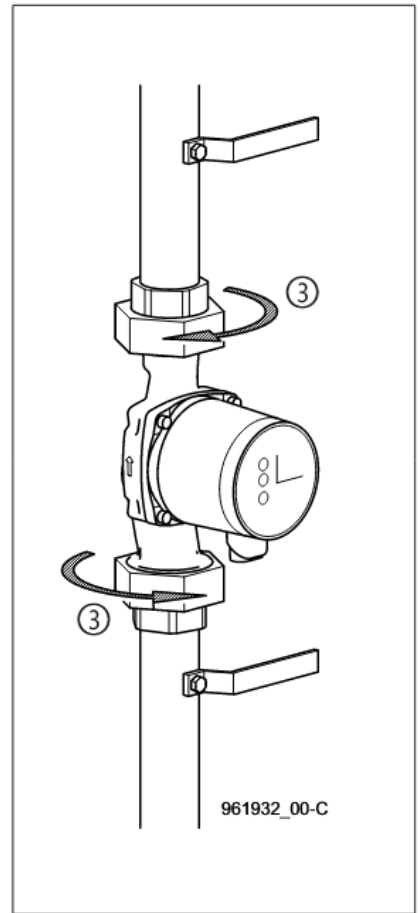
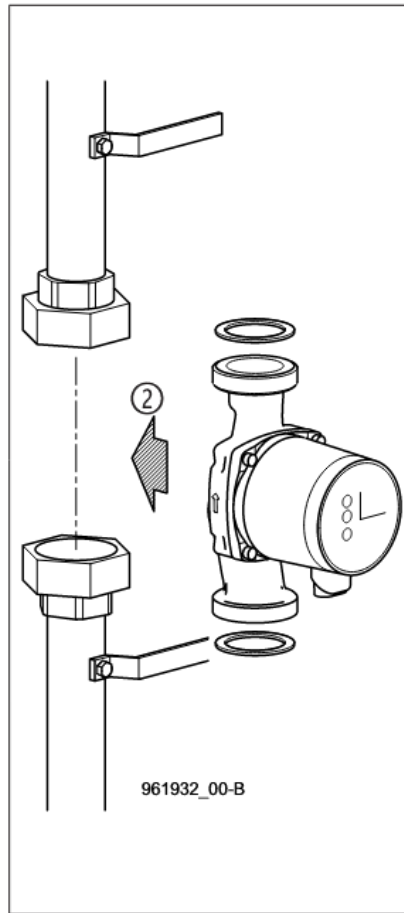
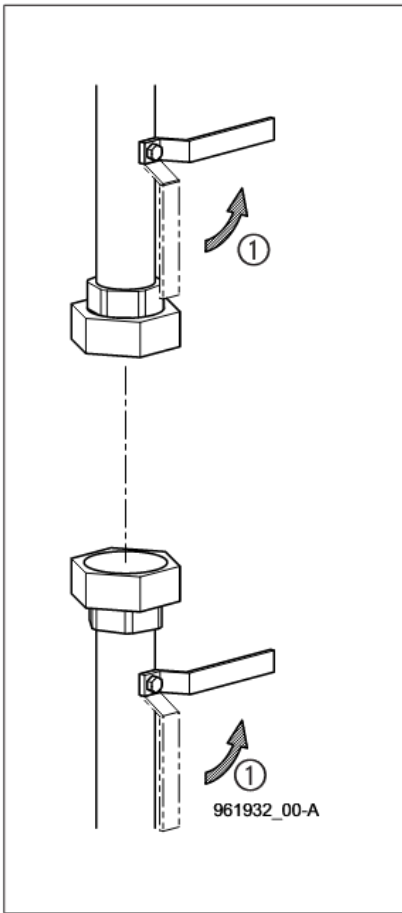

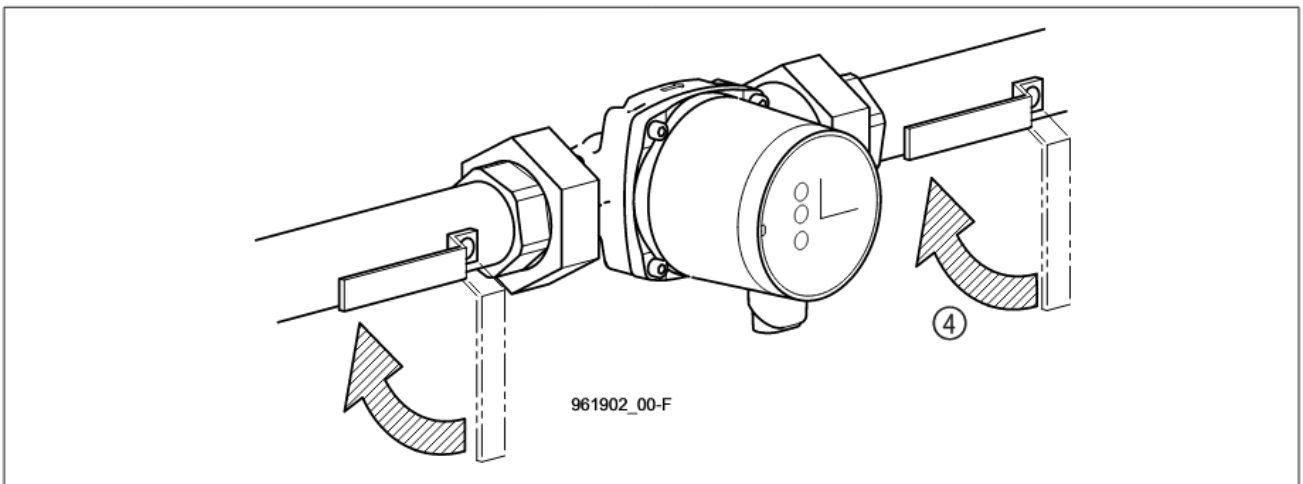
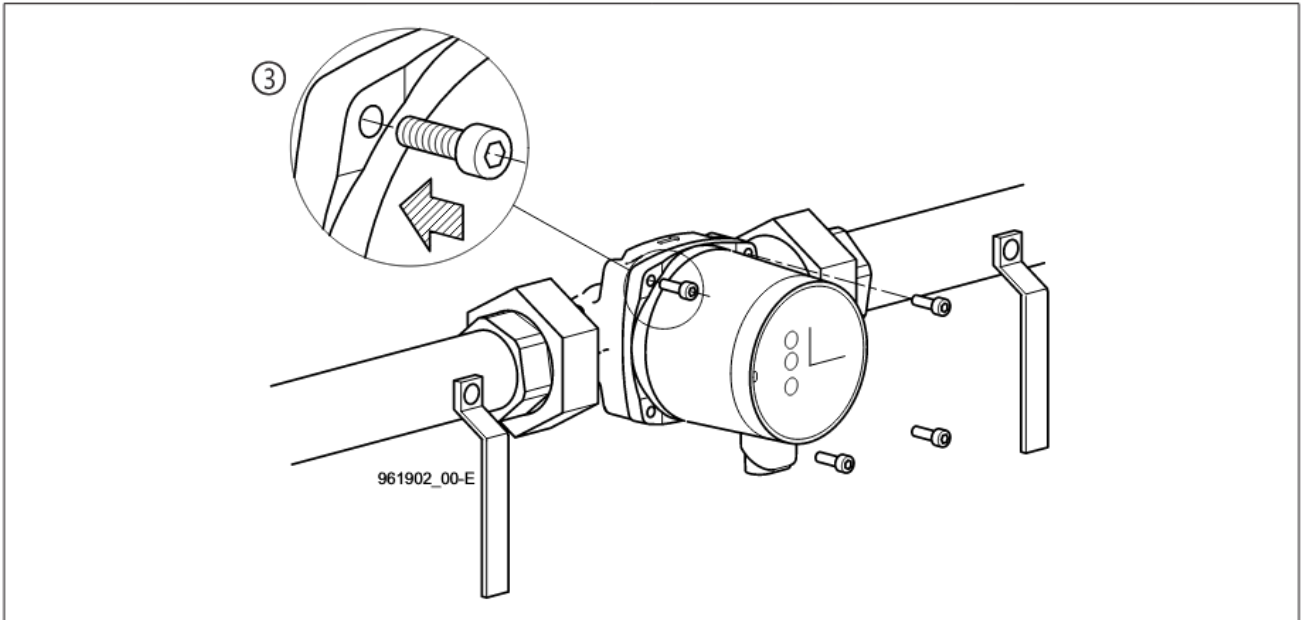
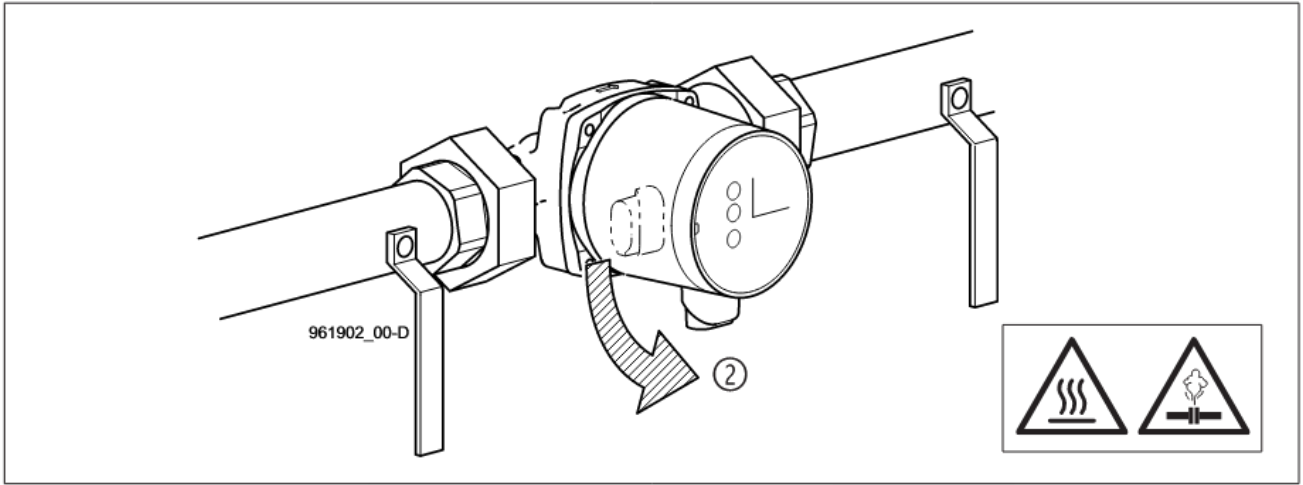

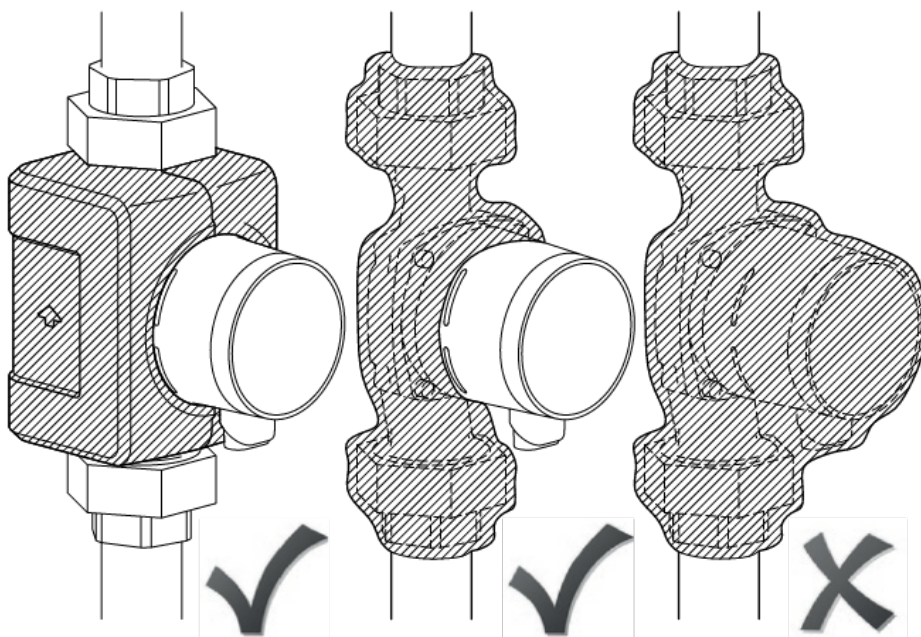
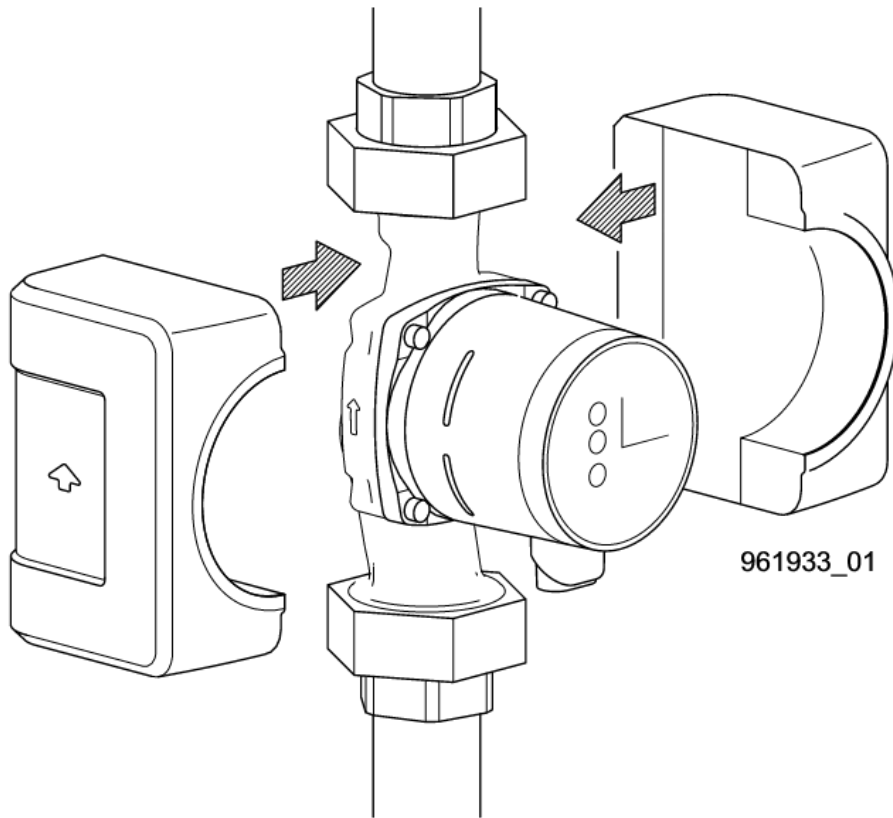

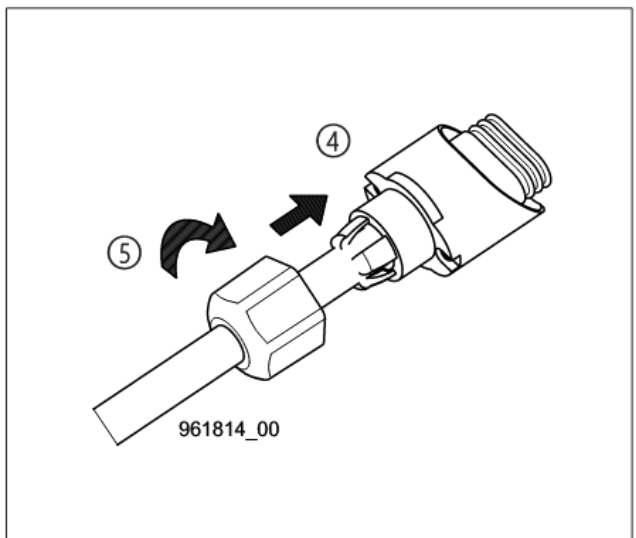
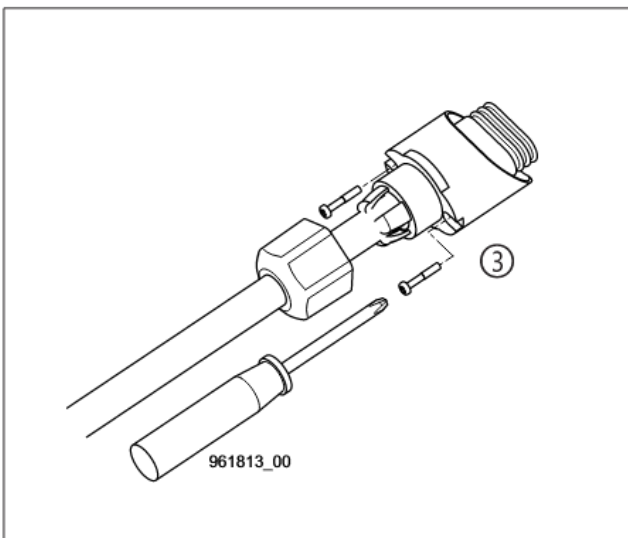
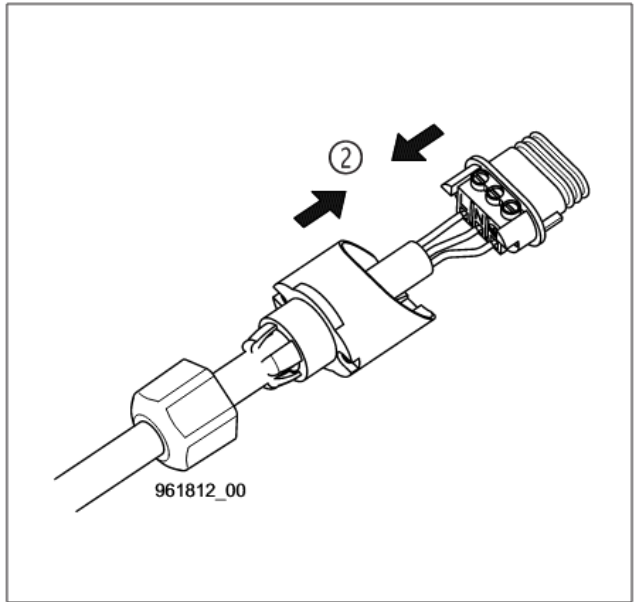
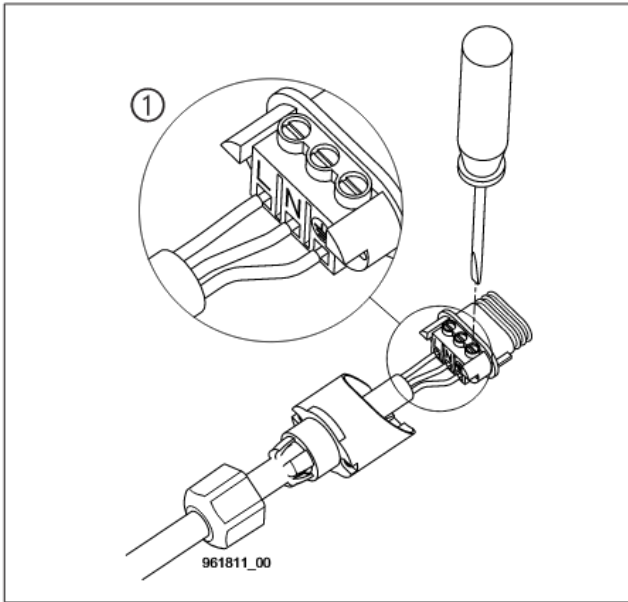
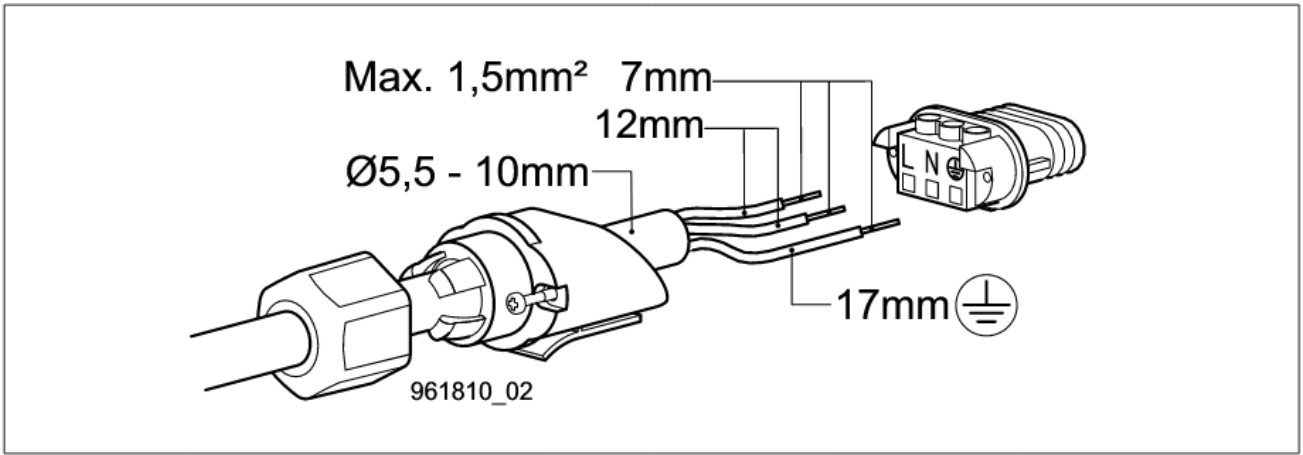

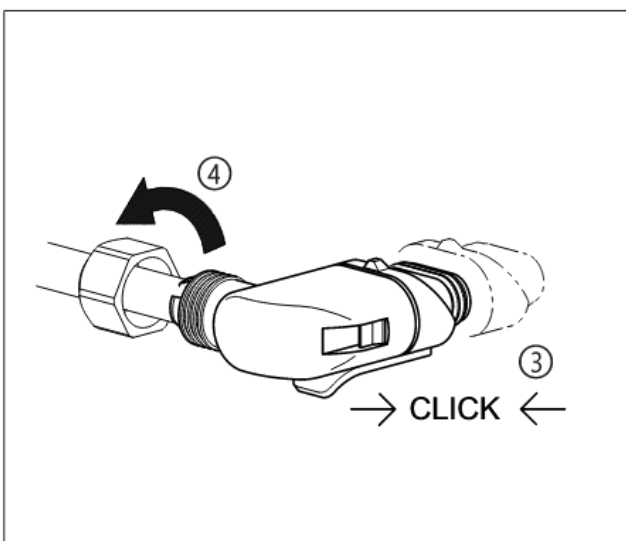
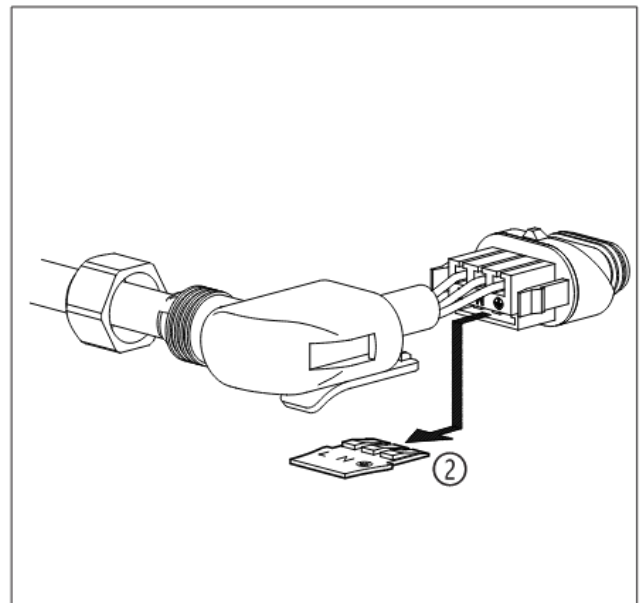
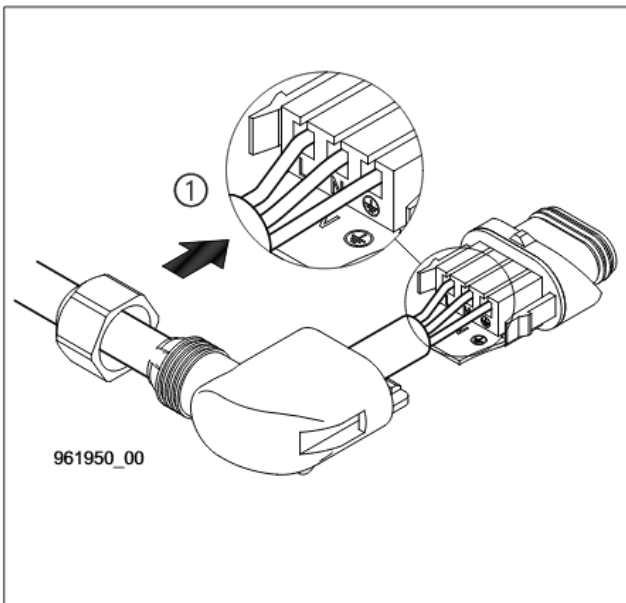
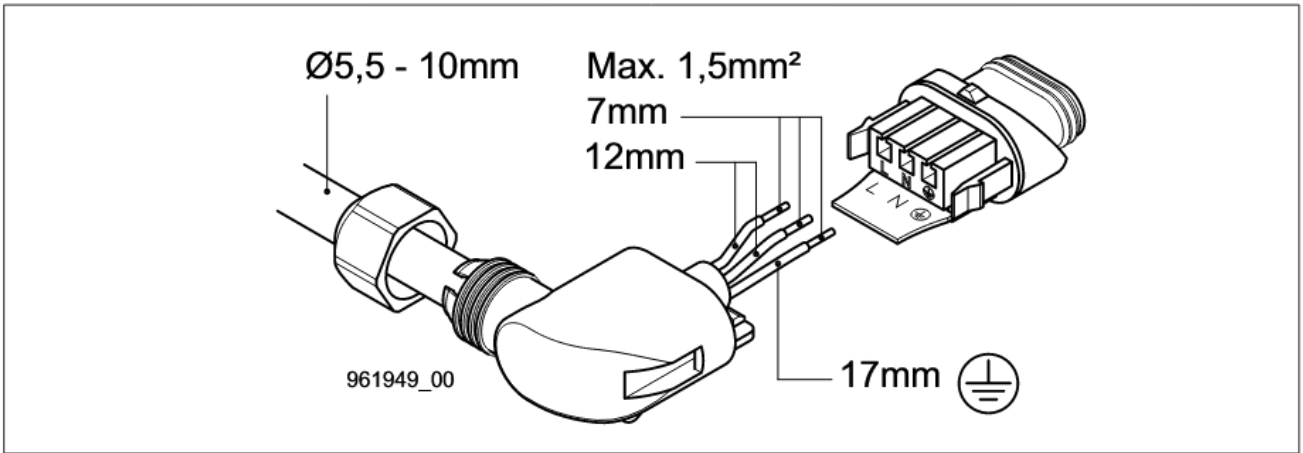

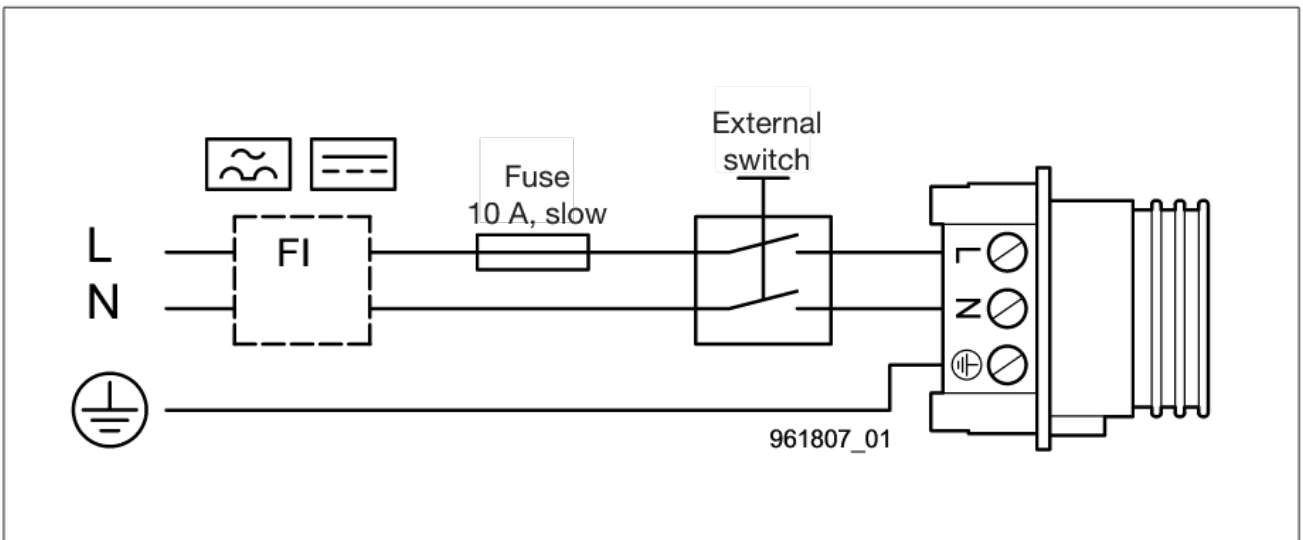
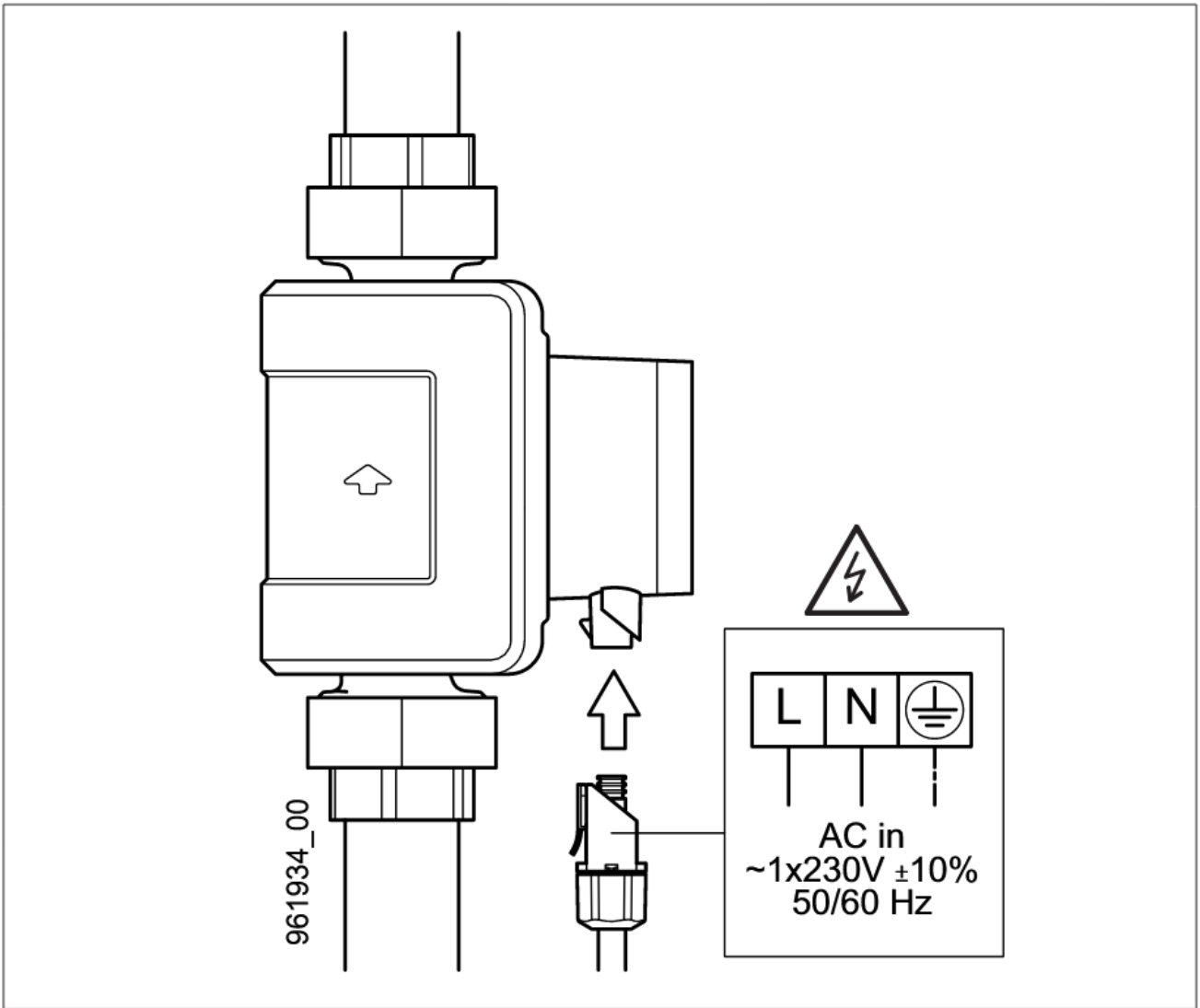



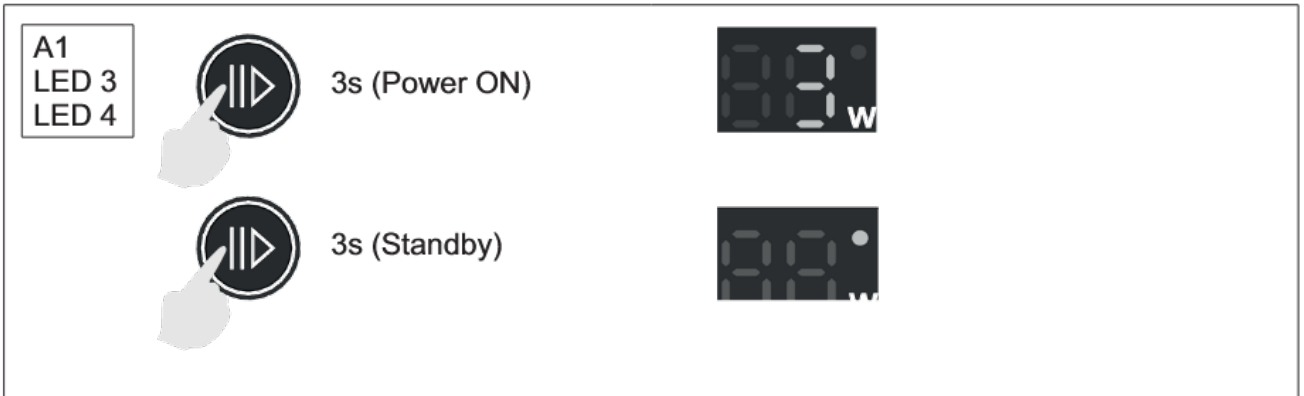
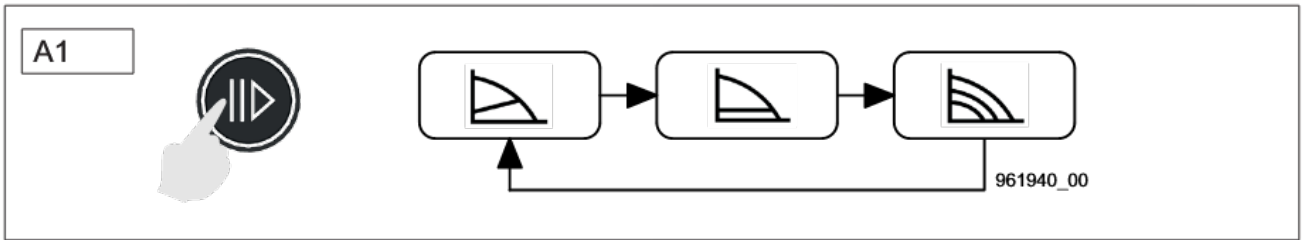
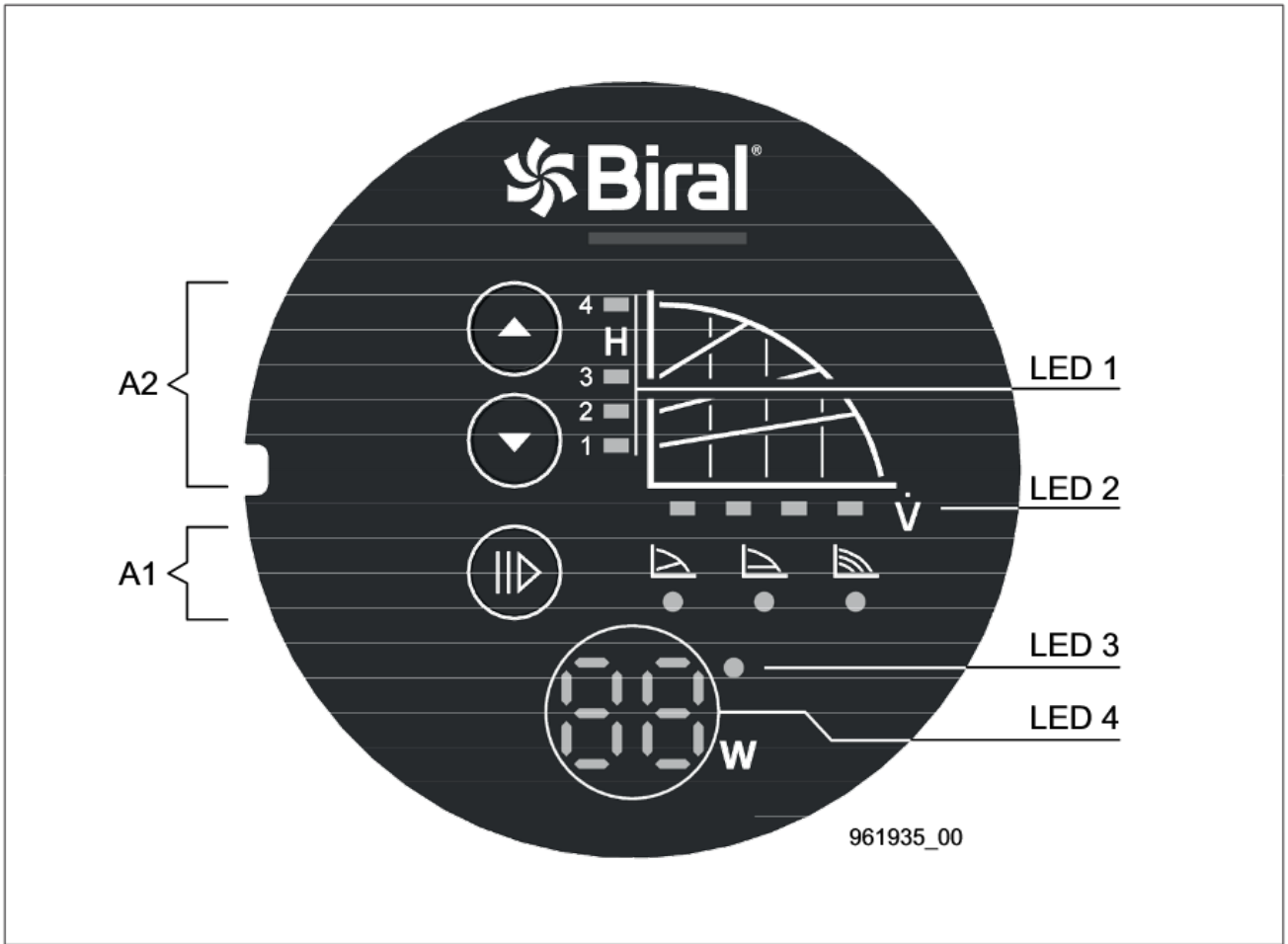



**A2 LED 1**

961941\_00

961939\_00

**LED 2**

25 %    50%    75%    100%

**A 2**





LED 3  
LED 4



Pumpe läuft  
Pompe en fonctionnement  
La pompa funziona  
Power ON  
Pomp loopt

Bomba funcionando  
Pompa funcționează  
Pompa pracuje  
Λειτουργία κυκλοφορητή  
Эксплуатация насоса



Betrieb Stopp  
Pompe ne fonctionne pas  
La pompa non funziona  
Standby  
Standby

Modo Standby  
Funcționare oprită  
Pompa zatrzymana  
Μη λειτουργία κυκλοφορητή  
Режим ожидания



Motor blockiert  
Moteur bloqué  
Motore bloccato  
Motor blocked  
Motor geblokkeerd

Motor bloqueado  
Motorul blocat  
Silnik zablokowany  
Μπλοκαρισμένο μοτέρ  
Двигатель заблокирован



Zu niedrige Versorgungs-  
spannung  
Alimentation trop faible  
Tensione di alimentazione  
troppo bassa  
Supply voltage too low  
Te lage voedingsspanning

Tensión de alimentación  
demasiado baja  
Tensiunea de alimentare este  
prea scăzută  
Zbyt niskie napięcie zasilania  
Η τάση τροφοδοσίας είναι  
πολύ χαμηλή  
Слишком низкое напряжение  
питания



Störung in der Elektronik  
Dérangement dans la partie  
électronique  
Guasto nell'elettronica  
Fault in the electronics  
Storing in de elektronica

Fallo en la electrónica  
Defecțiune electronică  
Usterka elektroniki  
Ηλεκτρονική βλάβη  
Ошибка электроники





**PrimAX xx-3 RED**

$P_1$	2 - 15 W
$I$	0.03 - 0.12 A

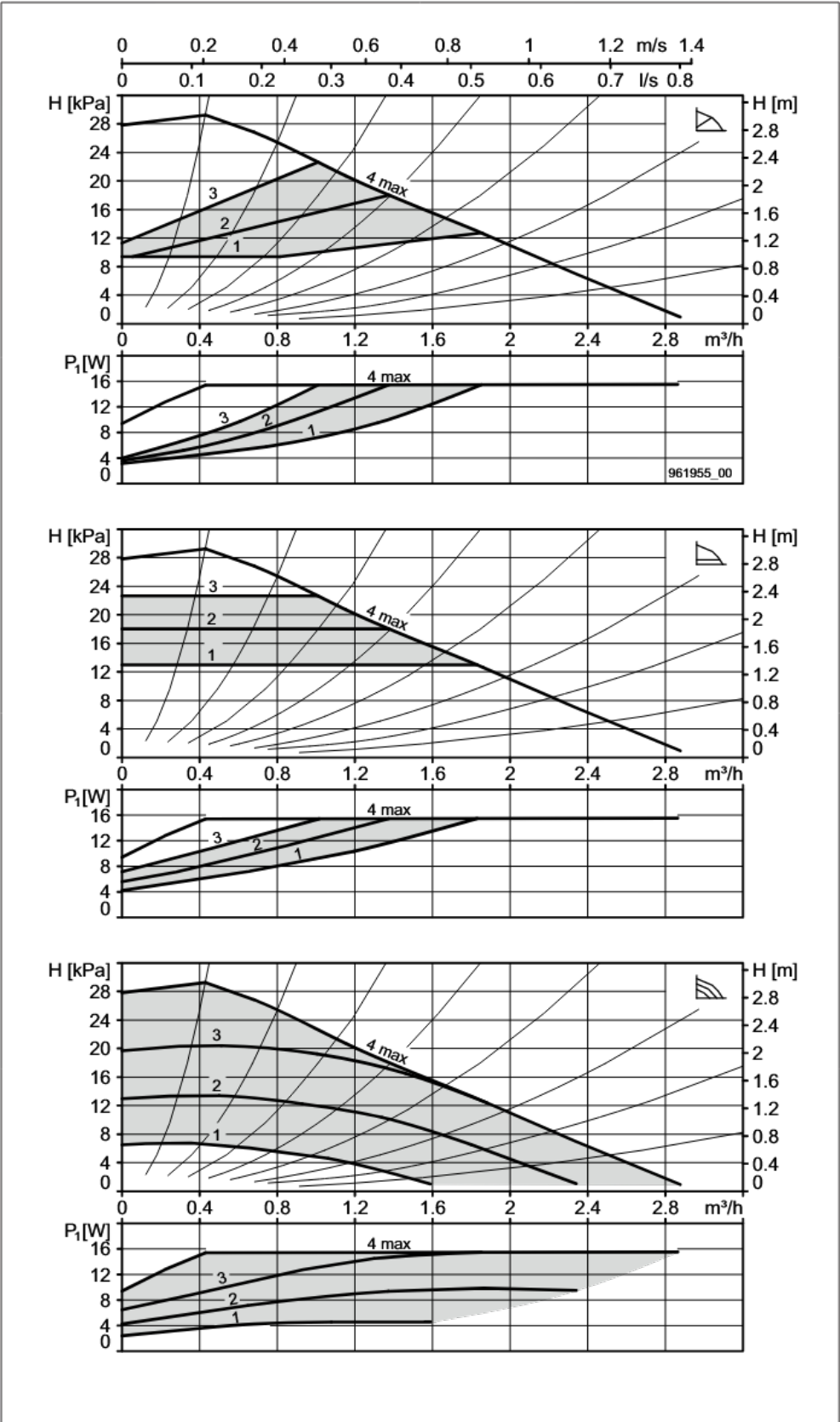



**PrimAX xx-4 RED**

$P_1$  3 - 18 W  
 $I$  0.03 - 0.15 A

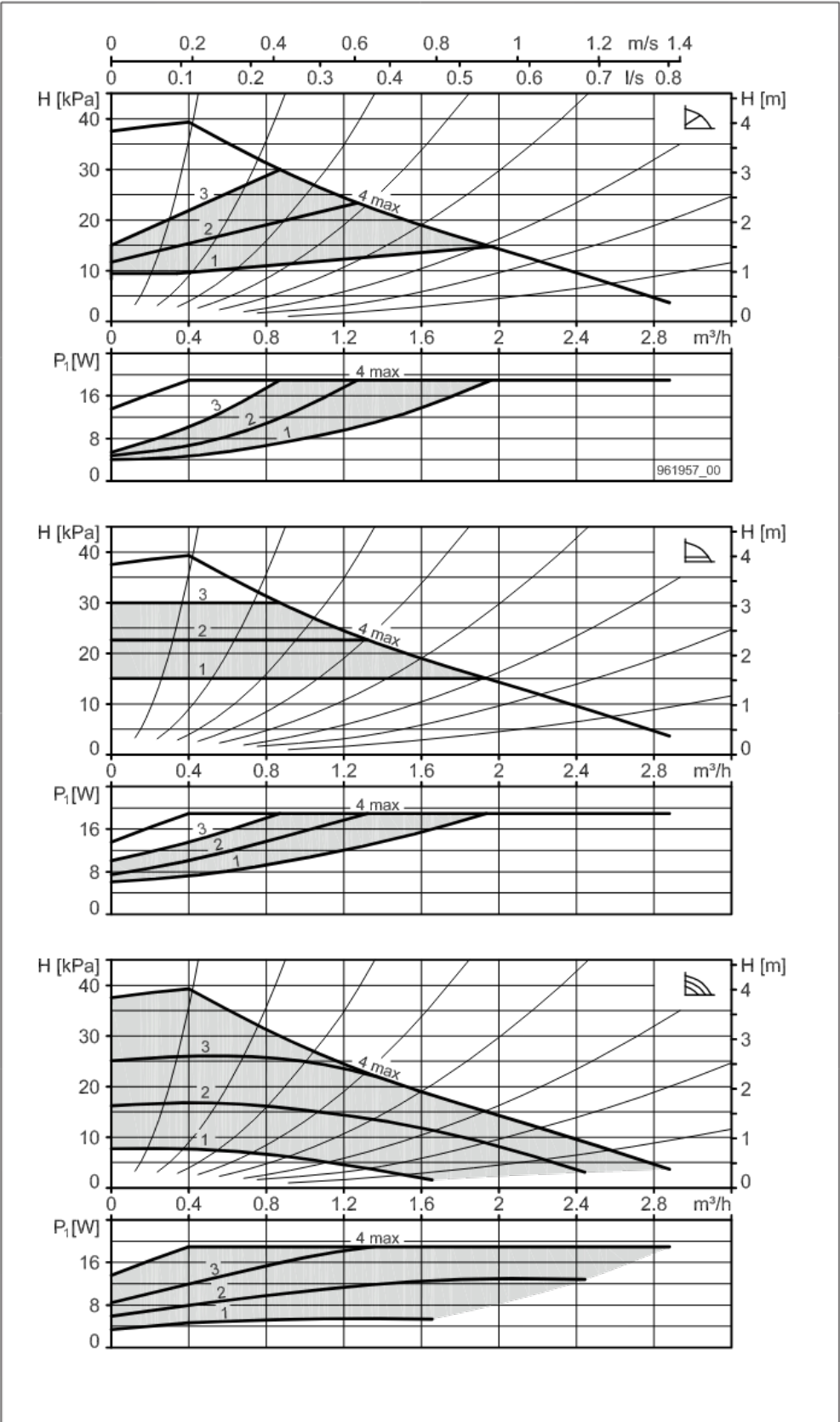



**PrimAX xx-6 RED**

$P_1$  3 - 34 W

I 0.03 - 0.27 A

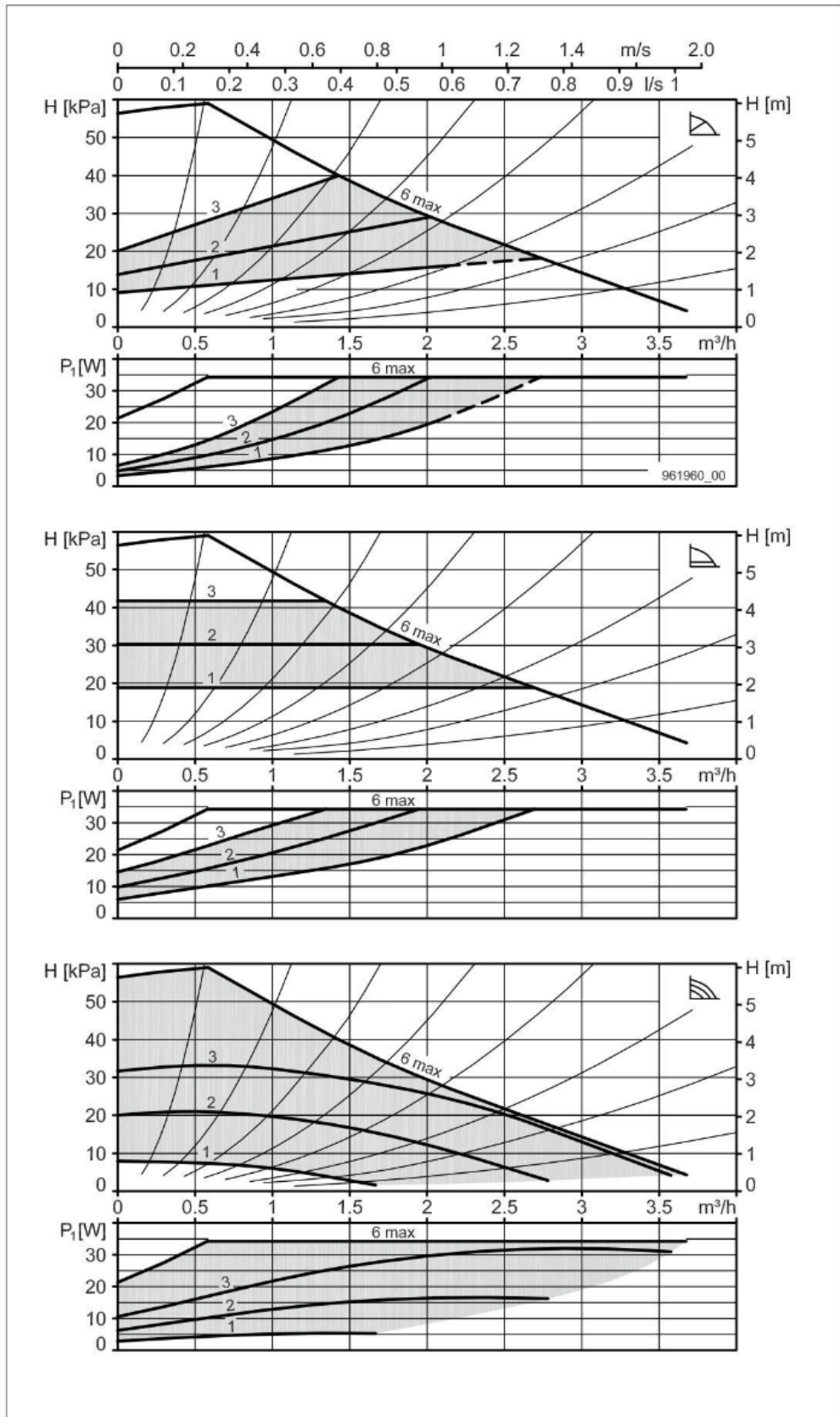





**PrimAX xx-8 RED**

$P_1$	3 - 50 W
$I$	0.03 - 0.41 A

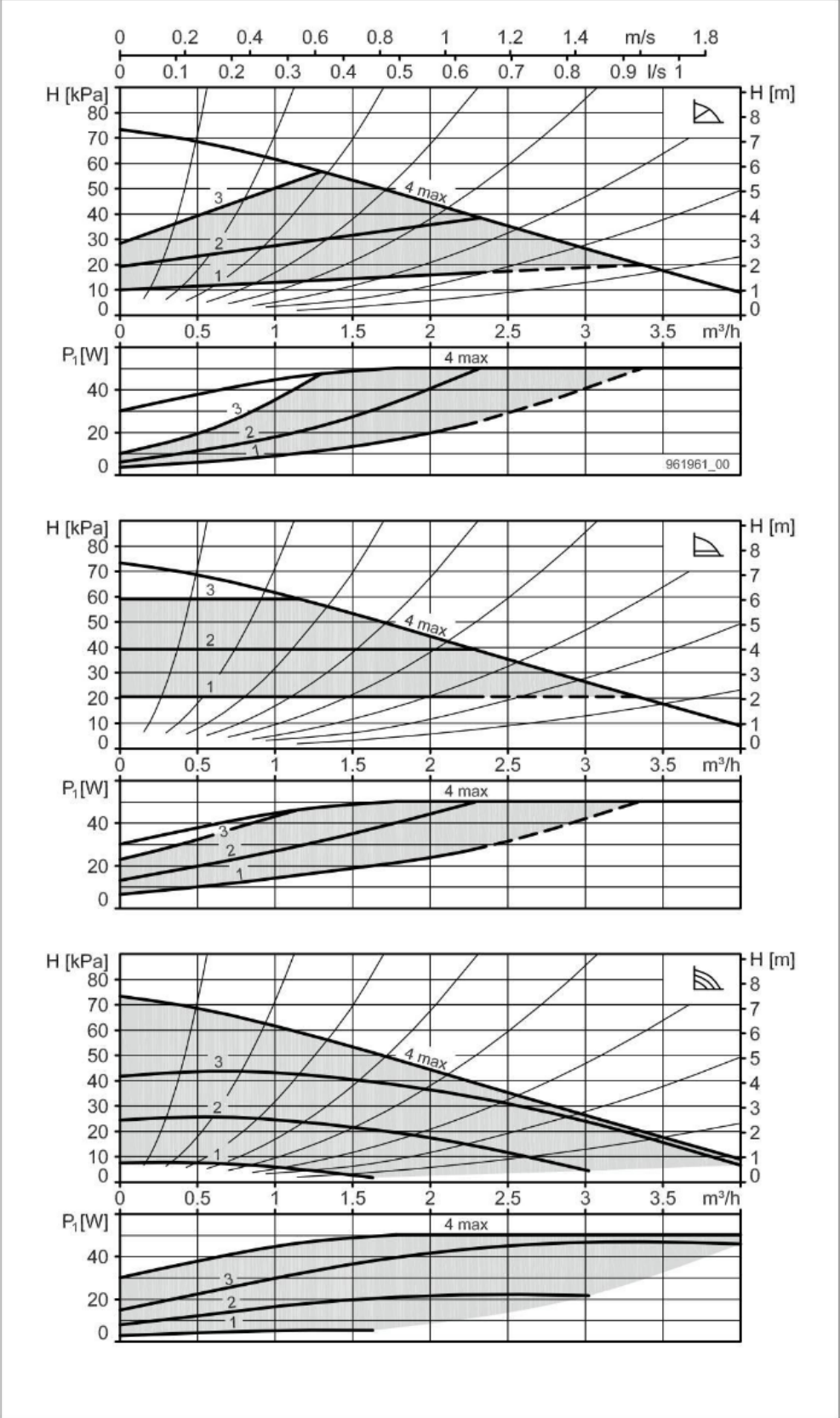

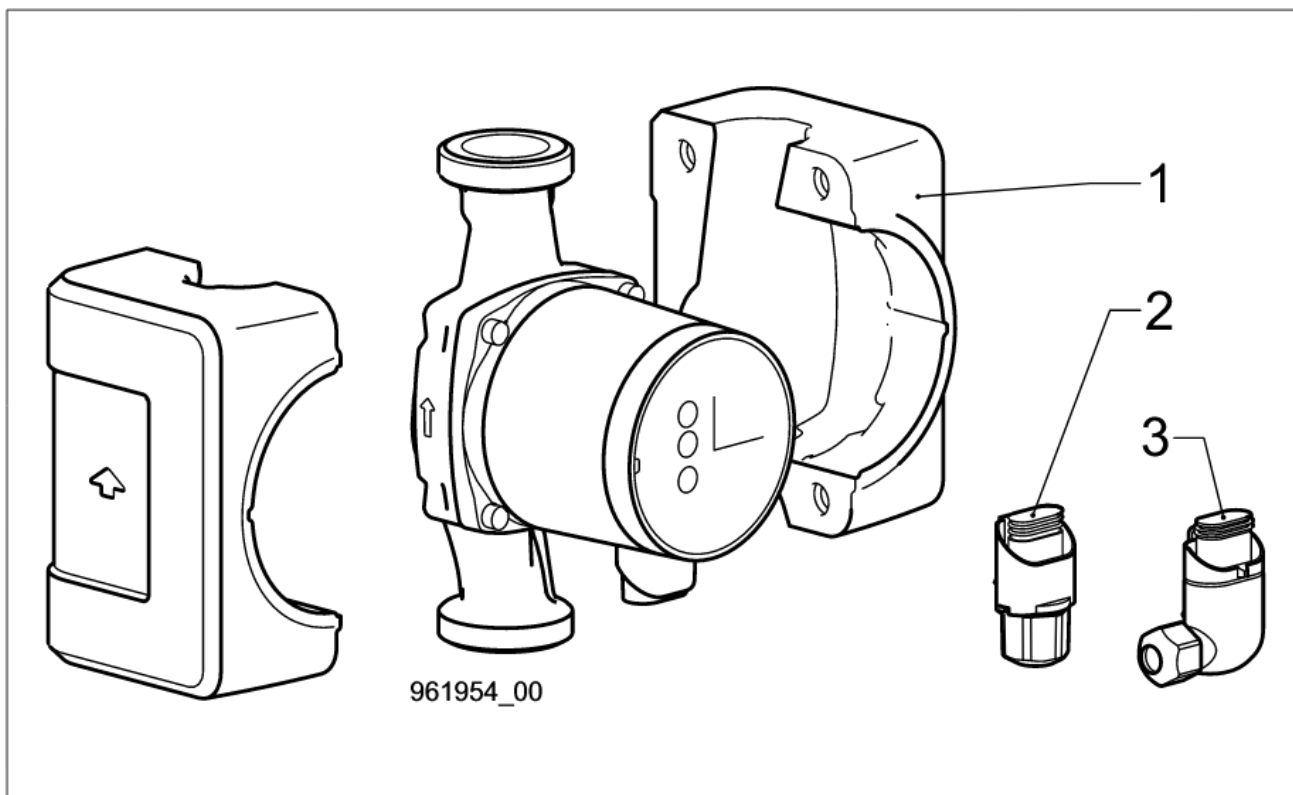

	Biral Art. No.		
PrimAX...	Pos. 1	Pos. 2	Pos. 3
PrimAX 15-x 130 RED	7000001533	2204400150	2205860150
PrimAX 25-x 130 RED			
PrimAX 25-x 180 RED	2205260150		
PrimAX 32-x 170 RED			
PrimAX 32-x 180 RED			





## Biral eDocuments

PrimAX 0805572011

### DE Weitere Informationen

Weitere Informationen Biral eDocuments, siehe Montage- und Betriebsanleitung PrimAX 0805572011

### FR Plus d'informations

Plus d'informations Biral eDocuments, voir les instructions d'installation et d'entretien, PrimAX 0805572011

### IT Maggiori informazioni

Maggiori informazioni Biral eDocuments, vedere le Istruzioni di installazione e funzionamento, PrimAX 0805572011

### EN Further information

Further information Biral eDocuments, see Installation and Operating Instructions, PrimAX 0805572011

### NL Meer informatie

Meer informatie Biral eDocuments, zie montage- en instructie voorschrift, PrimAX 0805572011

### ES Datos adicionales

Datos adicionales Biral eDocuments, ver Instrucciones de instalación y funcionamiento, PrimAX 0805572011

### RO Informații suplimentare

Informații suplimentare Biral eDocuments, vedea Instrucțiuni de montaj și exploatare, PrimAX 0805572011

### PL Dodatkowe informacje

should be "Dodatkowe informacje znajdziesz w Biral eDocuments, zobacz: Instrukcja montażu i eksploatacji, PrimAX 0805572011

### GR Περισσότερες πληροφορίες

Περισσότερες πληροφορίες στο Biral eDocuments, Δείτε τις Οδηγίες εγκατάστασης και λειτουργίας PrimAX 0805572011

### РУС Прочая информация

Прочая информация Biral eDocuments, увидеть Инструкции по установке и эксплуатации, PrimAX 0805572011



**Biral AG**

Südstrasse 10  
CH-3110 Münsingen  
T +41 31 720 90 00  
F +41 31 720 90 10  
info@biral.ch  
www.biral.ch

**Biral GmbH**

Kesselsgracht 7a  
D-52146 Würselen  
T +49 2405 408070  
F +49 2405 40807-19  
info@biral.de  
www.biral.de