

PNRZ 750.6 E(W) - PNRZ 1000.6 E(W)

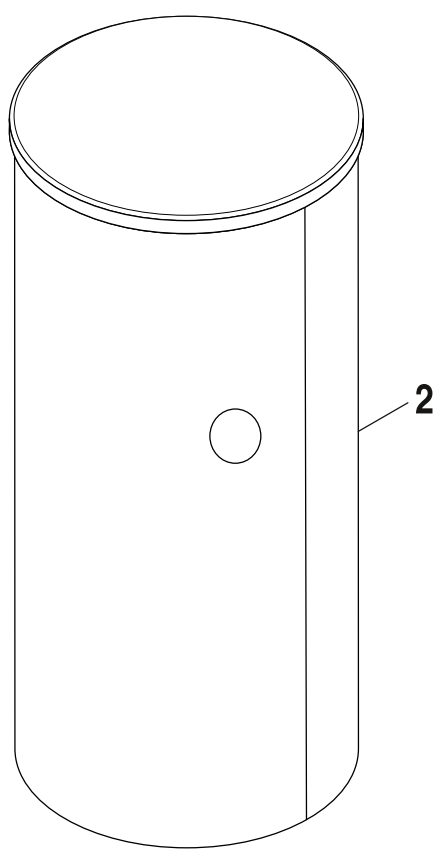

750 - 1000

8738893738.aa.RO

[de] Wichtige Hinweise zur Installation/Montage

Die Installation/Montage muss durch eine für die Arbeiten zugelassene Fachkraft unter Beachtung der geltenden Vorschriften erfolgen.

[en] Important notes on installation/assembly

The installation/assembly must be carried out by a qualified contractor, following these instructions and in compliance with the applicable regulations.

[fr] Instructions importantes pour l'installation/le montage

L'installation/le montage doit être effectué(e) par un spécialiste qualifié pour les opérations concernées et dans le respect de la présente notice et des prescriptions applicables.

[bg] Важни указания във връзка с инсталацията/монтажа

Инсталацията/монтажът трябва да се извършва от лицензиран за работите специалист в съответствие с настоящото ръководство и с приложимите разпоредби.

[cs] Důležité pokyny k instalaci/montáži

Instalaci/montáž musí při dodržení pokynů uvedených v tomto návodu a platných předpisů provést odborný pracovník s příslušným oprávněním pro tyto práce.

[da] Vigtige anvisninger til installationen/monteringen

Installationen/monteringen skal foretages af en godkendt installatør under overholdelse af denne vejledning og de gældende forskrifter.

[el] Σημαντικές υποδείξεις για την εγκατάσταση/συναρμολόγηση

Η εγκατάσταση/τοποθέτηση πρέπει να ανατίθεται σε εκπαιδευμένο για τις συγκεκριμένες εργασίες τεχνικό προσωπικό με τήρηση αυτών των οδηγιών καθώς και των σχετικών προδιαγραφών.

[es] Indicaciones importantes para instalación/montaje

La instalación/el montaje debe realizarla personal especializado que esté autorizado para realizar estos trabajos y que tenga en cuenta estas instrucciones y la normativa vigente.

[et] Olulised juhised paigaldamiseks/montaažiks

Paigaldamist/montaaži tohib läbi viia vaid selleks volitusi omav spetsialist, arvestades kehtivaid nõudeid.

[nl-BE] Belangrijke aanwijzingen betreffende de installatie/montage

De installatie/montage moet worden uitgevoerd door een voor de werkzaamheden geautoriseerde installateur rekening houdend met deze handleiding en de geldende voorschriften.

[fi] Tärkeitä asennus- ja kokoonpano-ohjeita

Näihin töihin hyväksytyt ammattiasentajan pitää suorittaa asennus- ja kokoonpanotyöt voimassa olevien määräysten mukaisesti.

[hu] Fontos tudnivalók az installáláshoz/szereléshez

A telepítést/szerelést egy, a munkálatokra felhatalmazott szakembernek kell végeznie, jelen utasítás és az érvényes előírások figyelembevételével.

[it] Avvertenze importanti per l'installazione/il montaggio

L'installazione/il montaggio deve aver luogo ad opera di una ditta specializzata ed autorizzata in osservanza di queste istruzioni e delle direttive vigenti.

[ka] მნიშვნელოვანი მითითებები ინსტალაციისთვის/მონტაჟისთვის

ინსტალაცია/მონტაჟი უნდა განხორციელდეს საშუალებისთვის დამკვეთი კვალიფიციური პერსონალის მიერ, მოქმედი განაწესის დაცვით.

[lt] Svarbios instaliavimo ir (arba) montavimo nuorodos

Instaliavimo / montavimo darbus, laikydamiės šios instrukcijos reikalavimų ir galiojančių taisyklių, privalo atlikti šioms darbams įgalioti specialistai.

[lv] Svarīgi norādījumi par iekārtas uzstādīšanu / montāžu

Uzstādīšanu/montāžu jāveic atbilstošajiem darbiem sertificētam speciālistam, ievērojot šo instrukciju un spēkā esošos noteikumus.

[nl] Belangrijke aanwijzingen betreffende de installatie/montage

De installatie/montage moet door een erkend installateur volgens de geldende voorschriften worden uitgevoerd.

[no] Viktig informasjon om installasjon/montering

Installasjonen/monteringen skal gjennomføres av autoriserte installatører, og installasjonsanvisningen samt gjeldende forskrifter skal følges.

[pl] Ważne wskazówki dotyczące instalacji/montażu

Instalację/montaż powinien wykonać specjalista uprawniony do tego typu prac z uwzględnieniem informacji podanych w niniejszej instrukcji oraz aktualnie obowiązujących przepisów.

[pt] Indicações importantes relativas à instalação/montagem

A instalação/montagem deve ser efectuada por um técnico autorizado para os trabalhos, respeitando este manual e as prescrições válidas.

[ro] Indicații importante privind instalarea/montajul

Instalarea/montajul trebuie realizate de către un specialist autorizat pentru lucrările respective, respectându-se prezentele instrucțiuni și prescripțiile valabile.

[ru] Важные указания по подключению/монтажу

Подключение/монтаж должны выполнять только специалисты, имеющие допуск к выполнению таких работ, при соблюдении требований этой инструкции и действующих норм и правил.

[sk] Dôležité pokyny týkajúce sa inštalácie/montáže

Inštaláciu/montáž musí vykonať odborný personál, ktorý má oprávnenie pre výkon týchto prác, pričom musí dodržiavať pokyny uvedené v tomto návode a platné predpisy.

[sl] Pomembni napotki za namestitvev/montažo

Inštalacijo/montažo lahko izvede samo pooblaščen strokovnjak ob upoštevanju teh navodil in veljavnih predpisov.

[sr] Važna uputstva za ugradnju i montažu

Ovu instalaciju/montažu moraju da obave stručna lica koja su ovlašćena za obavljanje takvih radova u skladu sa ovim uputstvom i važećim propisima.

[sv] Viktiga anvisningar för installation/montering

Installationen/monteringen måste utföras av en behörig och tekniskt utbildad person enligt denna anvisning samt gällande föreskrifter.

[tr] Kurulum/Montaj ile ilgili önemli uyarılar

Kurulum/montaj, bu çalışmalarını yapmasına müsaade edilen uzman kişiler tarafından işbu kılavuz ve geçerli yönetmelikler dikkate alınarak yapılmalıdır.

[uk] Важливі вказівки щодо установки/монтажу

Встановлення/монтаж повинні виконувати фахівці, що допущені до виконання таких робіт, із дотриманням цієї інструкції та діючих приписів.

[zh] 安装方面的重要提示

安装和组装工作必须由经过许可的专业人员进行，同时必须遵守本说明书和现行法规的相关要求

[ar] ملاحظات هامة للتركيب/التجميع
يجب أن يتم التركيب/التجميع من قبل متخصص مصرح له بالعمل، مع مراعاة اللوائح السارية.

[fa] تذکرات مهم درباره نصب/مونتاژ
نصب/مونتاژ باید توسط فردی حرفه ای که مجاز به انجام این کار است، و همچنین با توجه کامل به مقررات مربوطه انجام شود.









[az] Quraşdırılma

Quraşdırılma işinin yerinə yetirilməsi səlahiyyətli bir mütəxəssis tərəfindən və müvafiq qaydalara uyğun olaraq aparılmalıdır.

Ersatzteilliste
Spare parts list

Liste des pièces de rechange
Lista parti di ricambio

Onderdelenlijst
Lista de repuestos

- | | | | | | |
|----|---|----------|----|---|------------|
| 4x |  | 80x30x2 | 6x |  | D90x38x20 |
| 4x |  | 80x34x2 | 12 |  | D90x25x20 |
| 2x |  | 90x43x2 | |  | D140x58x20 |
| 2x |  | 100x48x2 | | | |
| 6x |  | 110x55x2 | | | |

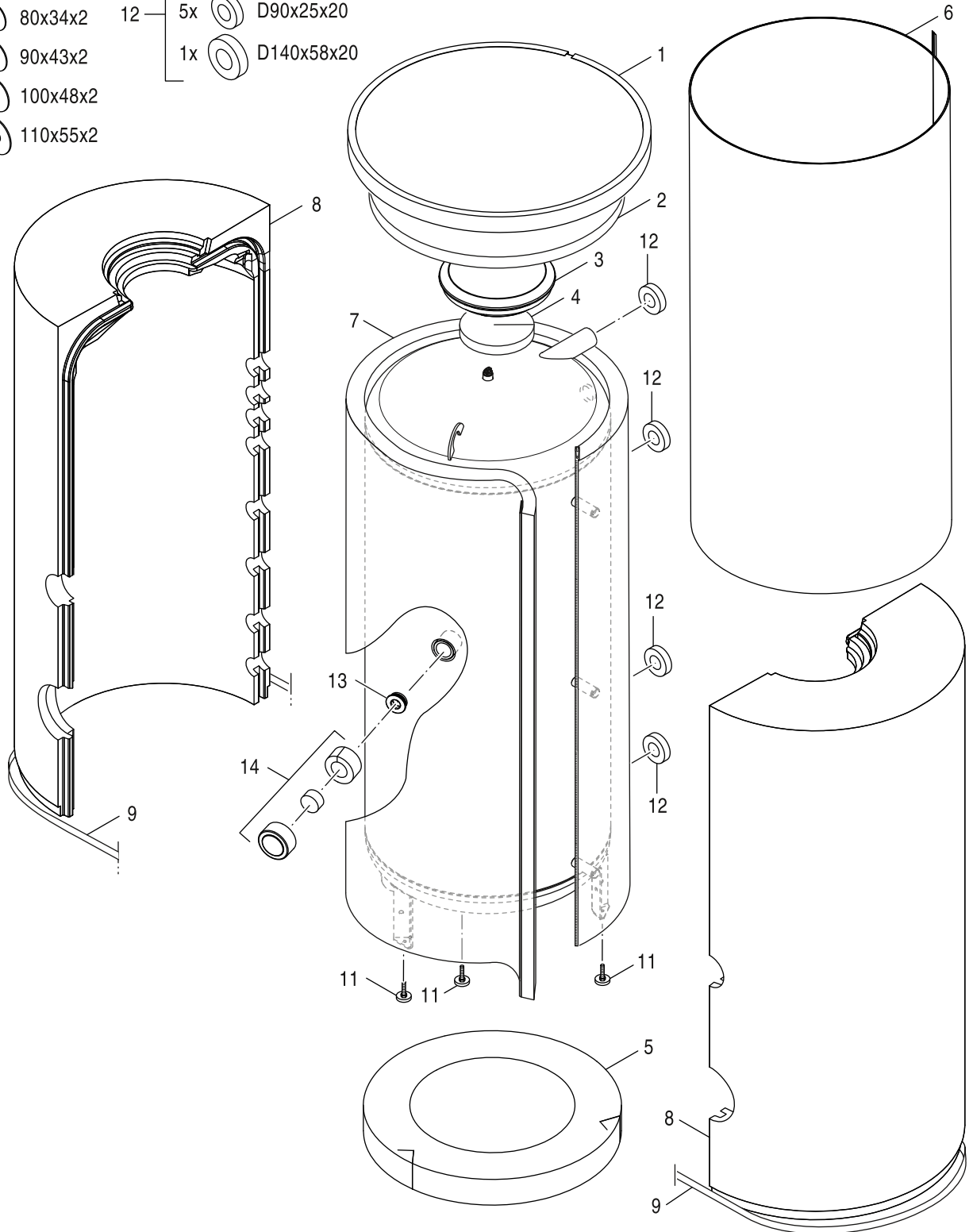

8738893739.aa.RO

2

Pufferspeicher PNRZ 750.6 E - 1000.6 E
 Buffer cylinder PNRZ 750.6 E - 1000.6 E
 Ballon tampon PNRZ 750.6 E - 1000.6 E
 Accumulatore puffer PNRZ 750.6E-1000.6E
 Bufferboiler PNRZ 750.6 E - 1000.6 E
 Acumulador auxiliar PNRZ 750.6E-1000.6E

PNRZ 750.6 E(W) - PNRZ 1000.6 E(W)

Pos	Bezeichnung Description Dénomination Descrizioni Benaming Descripción	Bestell-Nr. Ordering no. Numéro de commande N° d'ordine Bestelnummer Número el ordenar	PNRZ1000.6 E-C	PNRZ1000.6 E-E	PNRZ1000.6 EW-C	PNRZ1000.6 EW-E	PNRZ750.6 E-C	PNRZ750.6 E-E	PNRZ750.6 EW-C	PNRZ750.6 EW-E									Bemerkungen Remarks Remarques Osservazioni Opmerkingen Observaciones
1	Deckel 750/1000-80 schwarz everp	8 718 573 223 0	■	■	■	■	■	■											
1	Abdeckung Deckel D960 schwarz everp	8 735 100 309	■	■	■	■	■	■											
2	Isolierung Deckel 750/1000-80V everp	8 735 100 079	■	■	■	■	■	■											
3	Stopfen EPS Oberteil D370	8 718 541 763 0	■	■	■	■	■	■											
4	Weichschaum Rosette D280x0x50 everp	8 735 100 318	■	■	■	■	■	■											
5	Isolierung Boden D790x80V everp	8 735 100 077	■	■	■	■	■	■											
5	Isolierung Boden D820x100 everp	8 735 100 305	■	■	■	■	■	■											
6	Folienmantel P750 blau everp	8 735 100 594					■												
6	Folienmantel P750 weiß everp	8 735 100 595						■											
6	Folienmantel P1000 blau everp	8 735 100 596	■																
6	Folienmantel P1000 weiß everp	8 735 100 597		■															
7	Isolation Puffer 1000.5V E everp	8 735 100 572		■															
7	Isolation Puffer 1000.5VW E everp	8 735 100 573		■	■														
7	Isolation Puffer 750.5V E everp	8 735 100 575						■											
7	Isolation Puffer 750.5VW E everp	8 735 100 576						■	■										
8	Wärmeschutz Speicher PNRZ750-C everp	7 735 502 738					■	■											
8	Wärmeschutz Speicher PNRZ1000-C everp	7 735 502 758	■	■															
9	Spannband everp	8 735 100 317	■	■	■	■	■	■											
11	Zubehör Stellfuß Speicher 500-1000L 3 ST	8 718 590 658	■	■	■	■	■	■	■	■									
12	Set Weichschaum Rosetten P everp	8 735 100 598	■	■	■	■	■	■											
13	Stopfen G1 1/2" SW22 mit PTFE-Ring EVERP	8 735 101 094	■	■	■	■	■	■	■	■									
14	Abdeckung E-Muffe schwarz everp	8 735 100 312	■	■	■	■	■	■											
15	Set Rosetten selbstklebend S everp	8 735 100 321	■	■	■	■	■	■	■	■									
	Thermometer kpl 30-80 C	5 236 200	■	■	■	■	■	■	■	■									
	Rosetten Set E-Heizung	7 735 501 421	■	■	■	■	■	■	■	■									
	EPP-Abdeckung für Fühlerhülse verp	7 735 501 429	■	■	■	■	■	■	■	■									
	Digital-Thermometer DTA	7 747 201 004	■	■	■	■	■	■	■	■									
	Logo Buderus everp	8 718 224 253 0	■	■	■	■	■	■	■	■									
	Thermometergehäuse 3T verp	8 735 100 555	■	■	■	■	■	■	■	■									
	Thermometergehäuse 1T verp	8 735 100 556	■	■	■	■	■	■	■	■									

PNRZ 750.6 E(W) - PNRZ 1000.6 E(W)

Pufferspeicher PNRZ 750.6 E - 1000.6 E
 Buffer cylinder PNRZ 750.6 E - 1000.6 E
 Ballon tampon PNRZ 750.6 E - 1000.6 E
 Accumulatore puffer PNRZ 750.6E-1000.6E
 Bufferboiler PNRZ 750.6 E - 1000.6 E
 Acumulador auxiliar PNRZ 750.6E-1000.6E

Übersetzungsliste List of translations		Liste des traductions Traduzione delle descrizioni		Vertalinglijst Lista de traducciones	
Pos	Description	Denomination	Descrizione	Benaming	Descripción
2	Element of construction	Groupe de construction	Gruppo di costruzione	Montagegroep	Grupo de construcción
1	Cover 750/1000-80 black	Couvercle 750/1000-80 noir	Coperchio 750/1000-80 nero	Afdekking 750/1000-80 zwart	Recubrimiento 750/1000-80 negro
1	Cover Top 960 black packed	Couvercle Couvercle 960 noir	Copertura Coperchio 960 nero	Afdekking Deksel 960 zwart	Recubrimiento PR1000-80
2	Insulation 750/1000-80V top	Isolation 750/1000-80V Couvercle	Coibentazione 750/1000-80V Coperchio	Isolatie 750/1000-80V Deksel	Aislamiento 750/1000-80V Tapa
3	Plug EPS upper section D370	Bouchon EPS partie supérieure D370	Tappo EPS Parte superiore D370	Stop EPS bovendeel D370	Tapon EPS parte superior D370
4	Seal Foam Rose 280x0x50 packed	Mousse molle Rozet 280x0x50	Schiuma morbida Rosone 280x0x50	Zachtschuim Rozet 280x0x50	Espuma suave Rosetón 280x0x50
5	Insulation bottom D790x80V	Isolation bas D790x80V	Coibentazione sotto D790x80V	Isolatie onder D790x80V	Aislamiento debajo D790x80V
5	Insulation Bottom 820x100 packed	Isolation bas 820x100	Coibentazione sotto 820x100	Isolatie onder 820x100	Aislamiento debajo 820x100
6	Cover Jacket P750 blue packed	Habillage film P750 bleu	Pellicola di rivestimento P750 blu	Foliamantel P750 blauw	Plástico de protección P750 azul
6	Cover Jacket P750 white packed	Habillage film P750 blanc	Pellicola di rivestimento P750 bianco	Foliamantel P750 wit	Plástico de protección P750 blanco
6	Cover Jacket P1000 blue packed	Habillage film P1000 bleu	Pellicola di rivestimento P1000 blu	Foliamantel P1000 blauw	Plástico de protección P1000 azul
6	Cover Jacket P1000 white packed	Habillage film P1000 blanc	Pellicola di rivestimento P1000 bianco	Foliamantel P1000 wit	Plástico de protección P1000 blanco
7	Insulation Buffer 1000.5V E packed	Isolation Buffer 1000.5V E	Isolamento Buffer 1000.5V E	Isolatie Buffer 1000.5V E	Aislamiento Buffer 1000.5V E
7	Insulation Buffer 1000.5VW E packed	Isolation Buffer 1000.5VW E	Isolamento Buffer 1000.5VW E	Isolatie Buffer 1000.5VW E	Aislamiento Buffer 1000.5VW E
7	Insulation Buffer 750.5V E packed	Isolation Buffer 750.5V E	Isolamento Buffer 750.5V E	Isolatie Buffer 750.5V E	Aislamiento Buffer 750.5V E
7	Insulation Buffer 750.5VW E packed	Isolation Buffer 750.5VW E	Isolamento Buffer 750.5VW E	Isolatie Buffer 750.5VW E	Aislamiento Buffer 750.5VW E
8	Insulation Tank PNRZ750-C packed	Isolation ballon PNRZ750-C	Isolamento accumulatore PNRZ750-C	Isolatie boiler PNRZ750-C	Aislamiento acumulador PNRZ750-C
8	Insulation tank PNRZ1000-C sp	Isolation ballon PNRZ1000-C	Isolamento accumulatore PNRZ1000-C	Isolatie boiler PNRZ1000-C	Aislamiento acumulador PNRZ1000-C
9	Case Fixing packed	Sangle	Nastro tensore	Spanband	Cintas de sujeción
11	Foot Set Tank 500-1000L 3 pc	Pieds tampon 500-1000L - 3pc	Piedini regolabili bollitori - 3 pezzi	Stelvoeten	Pies adjustable
12	Seal Foam Rose P	Set Mousse molle Rozet P	Set Schiuma morbida Rosone P	Set Zachtschuim Rozet P	Set Espuma suave Rosetón P
13	Plug G1 1/2" SW22 with PTFE-RING SP	Bouchon G1 1/2" SW22 PTFE joints	Tappo G1 1/2" SW22 con anello di PTFE	Pluggen G1 1/2" SW22 met PTFE-ring	Tapón G1 1/2" SW22 con anillo de PTFE
14	Cover E-sleeve Black packed	Couvercle manchon chauffé électrique - noir	Copertura Riscaldamento manicotto - nero	Afdekking Elektrisch verwarm. mouw zwart	Recubrimiento - negro
15	Set rosettes self-adhesive S packed	Set rosettes auto-adhésif S	Set rosette autoadesive S	Set rozetten zelfklevende S	Set Rosetas autoadhesiva S
	Thermometer 30 - 80 degree C	Thermometre 30-80#c pour LT	Termometro 30-80 gradi C	Thermometer TBS L/LT horizontaal	Termómetro analogico horizontal
	Bezel Set E-heater	Set de rosettes élément chauffant électr	Rosette per resistenze elettriche	Set rozetten elektr. verwarmingselement	Conjunto de 2 rosetas pretas
	Cover Socket EPP packed	Couvercle Boîtier EPP	Copertura Boccola EPP	Afdekking Huls EPP	Recubrimiento Manguito EPP
	Digital thermometer with capillary 3 DTA	Thermom#tre numérique DTA	SONDA BOLLITORE DIGITALE DTA	THERMOMETER DIGITAAL P500/750/100-120S	Termometro Digital SU750
	Logo Buderus	Logo Buderus	Logo Buderus	Logo Buderus	Logo Buderus
	Case Thermometer 3T packed	Thermom#tre boîtier 3T	Termometro Involucro 3T	Thermometer behuizing 3T	Termómetro carcasa 3T
	Case Thermometer 1T packed	Thermom#tre boîtier 1T	Termometro Involucro 1T	Thermometer behuizing 1T	Termómetro carcasa 1T

Gerätetypen Types of appliances	Types de chaudières Tipo apparecchi	Toesteltypes Tipos de aplicaciones	Bemerkungen Remarks Remarques Osservazioni Opmerkingen Observaciones
Gerät Appliance Chaudière Apparecchio Toestel Aparato	Bestell-Nr. Ordering no. Numéro de commande N° d'ordine Bestelnummer Número el ordenar	Land Country Pays Paese Land Paese	
PNRZ1000.6 E-C	7 735 500 996	Belgien, Deutschland, Dänemark, Estland, Fra	
PNRZ1000.6 EW-C	7 735 500 997	Belgien, Deutschland, Dänemark, Estland, Fra	
PNRZ750.6 E-C	7 735 500 988	Belgien, Deutschland, Dänemark, Estland, Fra	
PNRZ750.6 EW-C	7 735 500 989	Belgien, Deutschland, Dänemark, Estland, Fra	
Puffer PNRZ1000.6 E-E	8 735 100 445	Deutschland, Polen	
Puffer PNRZ750.6 E-E	8 735 100 443	Deutschland, Polen	
PNRZ1000.6 E-E	7 735 500 992	Polen, Ukraine	
PNRZ1000.6 EW-E	7 735 500 993	Polen, Ukraine	
PNRZ750.6 E-E	7 735 500 984	Polen, Ukraine	
PNRZ750.6 EW-E	7 735 500 985	Polen, Ukraine	

Bosch Thermotechnik GmbH
Sophienstr. 30-32
D-35576 Wetzlar / Germany

Buderus