

GB125 18-60kW V4

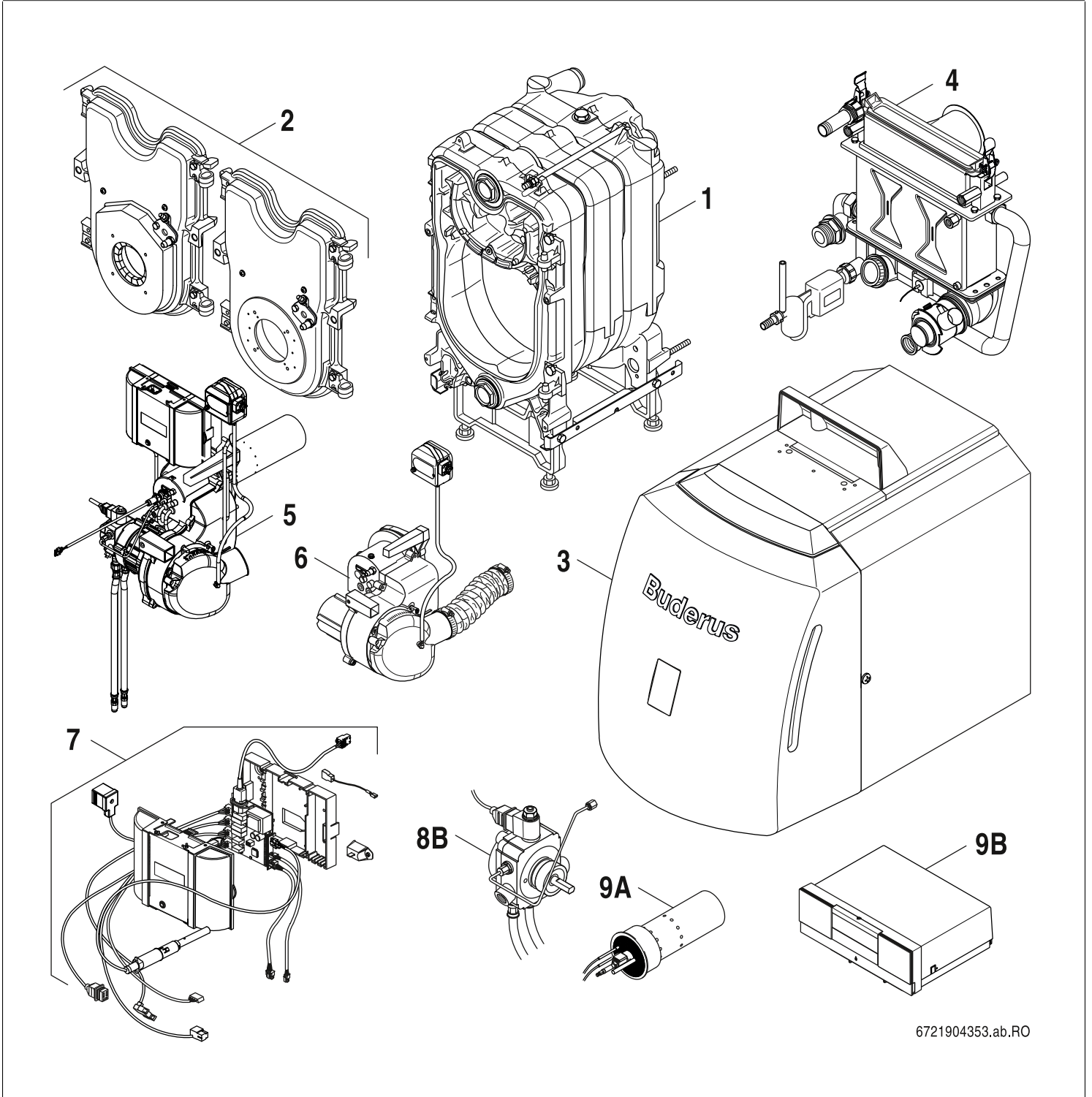

6721904353.ab.RO

[de] Wichtige Hinweise zur Installation/Montage

Die Installation/Montage muss durch eine für die Arbeiten zugelassene Fachkraft unter Beachtung der geltenden Vorschriften erfolgen.

[en] Important notes on installation/assembly

The installation/assembly must be carried out by a qualified contractor, following these instructions and in compliance with the applicable regulations.

[fr] Instructions importantes pour l'installation/le montage

L'installation/le montage doit être effectué(e) par un spécialiste qualifié pour les opérations concernées et dans le respect de la présente notice et des prescriptions applicables.

[bg] Важни указания във връзка с инсталацията/монтажа

Инсталацията/монтажът трябва да се извършва от лицензиран за работите специалист в съответствие с настоящото ръководство и с приложените разпоредби.

[cs] Důležité pokyny k instalaci/montáži

Instalaci/montáž musí při dodržení pokynů uvedených v tomto návodu a platných předpisů provést odborný pracovník s příslušným oprávněním pro tyto práce.

[da] Vigtige anvisninger til installationen/monteringen

Installationen/monteringen skal foretages af en godkendt installatør under overholdelse af denne vejledning og de gældende forskrifter.

[el] Σημαντικές υποδείξεις για την εγκατάσταση/συναρμολόγηση

Η εγκατάσταση/τοποθέτηση πρέπει να ανατίθεται σε εκπαιδευμένο για τις συγκεκριμένες εργασίες τεχνικό προσωπικό με τήρηση αυτών των οδηγιών καθώς και των σχετικών προδιαγραφών.

[es] Indicaciones importantes para instalación/montaje

La instalación/el montaje debe realizarla personal especializado que esté autorizado para realizar estos trabajos y que tenga en cuenta estas instrucciones y la normativa vigente.

[et] Olulised juhised paigaldamiseks/montaažiks

Paigaldamist/montaaži tohib läbi viia vaid selleks volitusi omav spetsialist, arvestades kehtivaid nõudeid.

[nl-BE] Belangrijke aanwijzingen betreffende de installatie/montage

De installatie/montage moet worden uitgevoerd door een voor de werkzaamheden geautoriseerde installateur rekening houdend met deze handleiding en de geldende voorschriften.

[fi] Tärkeitä asennus- ja kokoonpano-ohjeita

Näihin töihin hyväksytyt ammattiasentajan pitää suorittaa asennus- ja kokoonpanotyöt voimassa olevien määräysten mukaisesti.

[hu] Fontos tudnivalók az installáláshoz/szereléshez

A telepítést/szerelést egy, a munkálatokra felhatalmazott szakembernek kell végeznie, jelen utasítás és az érvényes előírások figyelembevételével.

[it] Avvertenze importanti per l'installazione/il montaggio

L'installazione/il montaggio deve aver luogo ad opera di una ditta specializzata ed autorizzata in osservanza di queste istruzioni e delle direttive vigenti.

[ka] მნიშვნელოვანი მითითებები ინსტალაციისთვის/მონტაჟისთვის

ინსტალაცია/მონტაჟი უნდა განხორციელდეს სამუშაოებისთვის დაშვებული კვალიფიციური პერსონალის მიერ, მოქმედი განაცხადის დაცვით.

[lt] Svarbios instaliavimo ir (arba) montavimo nuorodos

Instaliavimo/montavimo darbus, laikydamiesi šios instrukcijos reikalavimų ir galiojančių taisyklių, privalo atlikti šiems darbams įgalioti specialistai.

[sq] Shënime të rëndësishme për instalimin/montimin

Instalimi/montimi duhet të bëhet nga një kontraktues i kualifikuar, duke ndjekur këto udhëzime dhe në përputhje me rregulloret në fuqi.

[lv] Svarīgi norādījumi par iekārtas uzstādīšanu / montāžu

Uzstādīšanu/montāžu jāveic atbilstošajiem darbiem sertificētam speciālistam, ievērojot šo instrukciju un spēkā esošos noteikumus.

[nl] Belangrijke aanwijzingen betreffende de installatie/montage

De installatie/montage moet door een erkend installateur volgens de geldende voorschriften worden uitgevoerd.

[no] Viktig informasjon om installasjon/montering

Installasjonen/monteringen skal gjennomføres av autoriserte installatører, og installasjonsanvisningen samt gjeldende forskrifter skal følges.

[pl] Ważne wskazówki dotyczące instalacji/montażu

Instalację/montaż powinien wykonać specjalista uprawniony do tego typu prac z uwzględnieniem informacji podanych w niniejszej instrukcji oraz aktualnie obowiązujących przepisów.

[pt] Indicações importantes relativas à instalação/montagem

A instalação/montagem deve ser efectuada por um técnico autorizado para os trabalhos, respeitando este manual e as prescrições válidas.

[ro] Indicații importante privind instalarea/montajul

Instalarea/montajul trebuie realizate de către un specialist autorizat pentru lucrările respective, respectându-se prezentele instrucțiuni și prescripțiile valabile.

[ru] Важные указания по подключению/монтажу

Подключение/монтаж должны выполнять только специалисты, имеющие допуск к выполнению таких работ, при соблюдении требований этой инструкции и действующих норм и правил.

[sk] Dôležité pokyny týkajúce sa inštalácie/montáže

Inštaláciu/montáž musí vykonať odborný personál, ktorý má oprávnenie pre výkon týchto prác, pričom musí dodržiavať pokyny uvedené v tomto návode a platné predpisy.

[sl] Pomembni napotki za namestitvev/montažo

Inštalacijo/montažo lahko izvede samo pooblaščen strokovnjak ob upoštevanju teh navodil in veljavnih predpisov.

[sr] Važna uputstva za ugradnju i montažu

Ovu instalaciju/montažu moraju da obave stručna lica koja su ovlašćena za obavljanje takvih radova u skladu sa ovim uputstvom i važećim propisima.

[sv] Viktiga anvisningar för installation/montering

Installationen/monteringen måste utföras av en behörig och tekniskt utbildad person enligt denna anvisning samt gällande föreskrifter.

[tr] Kurulum/Montaj ile ilgili önemli uyarılar

Kurulum/montaj, bu çalışmalarını yapmasına müsaade edilen uzman kişiler tarafından işbu kılavuz ve geçerli yönetmelikler dikkate alınarak yapılmalıdır.

[uk] Важливі вказівки щодо установки/монтажу

Встановлення/монтаж повинні виконувати фахівці, що допущені до виконання таких робіт, із дотриманням цієї інструкції та діючих приписів.

[zh] 安装方面的重要提示

安装和组装工作必须由经过许可的专业人员进行，同时必须遵守本说明书和现行法规的相关要求

[ar] ملاحظات هامة للتثبيت/التجميع
يجب أن يتم التثبيت/التجميع من قبل متخصص مصرح له بالعمل، مع مراعاة اللوائح السارية.

[fa] تذکرات مهم درباره نصب/مونتاژ
نصب/مونتاژ باید توسط فردی حرفه ای که مجاز به انجام این کار است، و همچنین با توجه کامل به مقررات مربوطه انجام شود.

[az] Quraşdırılma

Quraşdırılma işinin yerinə yetirilməsi səlahiyyətli bir mütəxəssis tərəfindən və müvafiq qaydalara uyğun olaraq aparılmalıdır.

Ersatzteilliste
Spare parts list

Liste des pièces de rechange

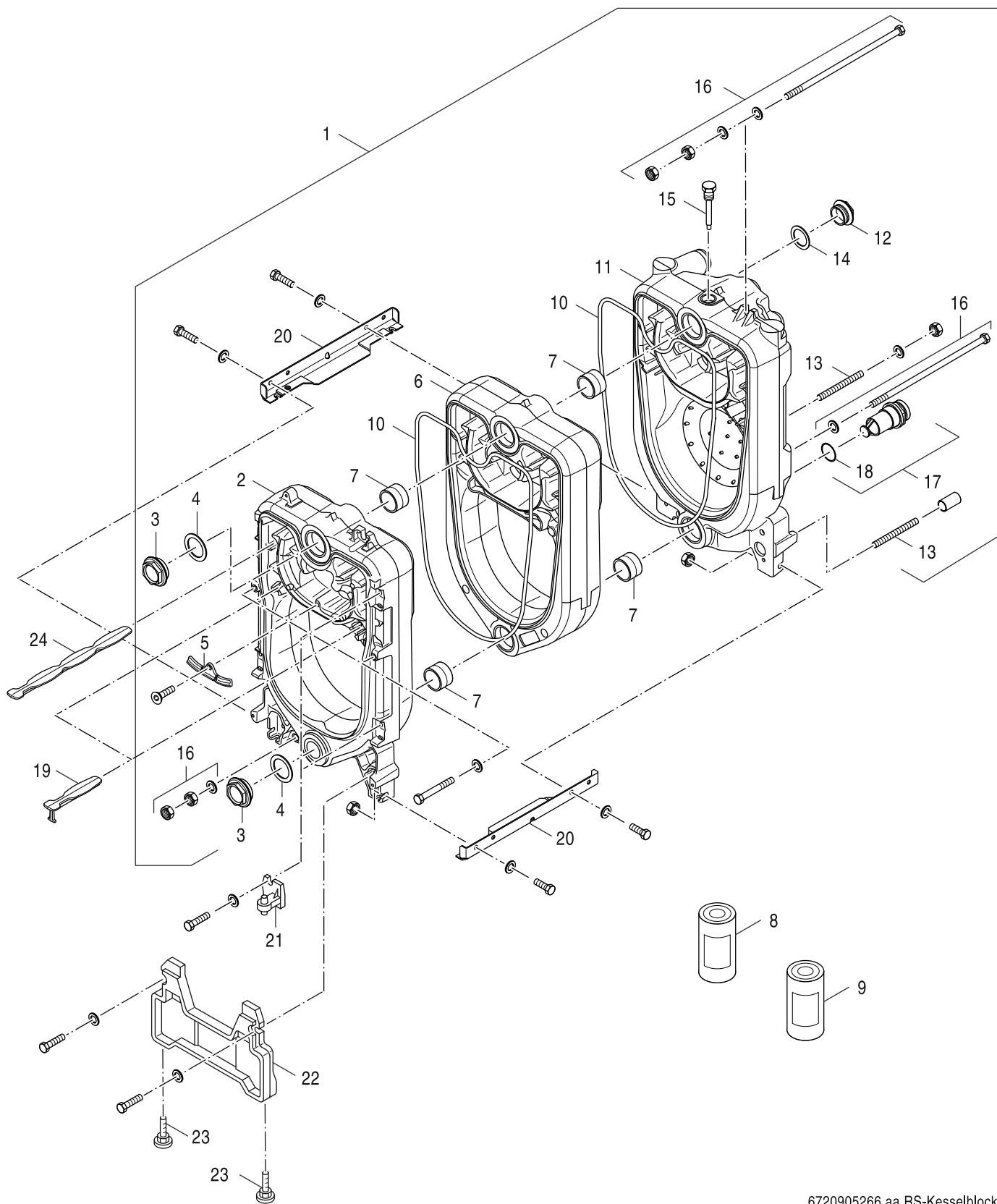

6720905266.aa.RS-Kesselblock

Kesselblock
Boiler block
Corps de chauffe

GB125 18-60kW V4

1

Pos	Bezeichnung Description Dénomination								Bemerkungen Remarks Remarques
			GB125 18/2	GB125 22/2	GB125 30/3	GB125 35/4	GB125 49/5	GB125 60/6	
1	Kesselblock 6Gld vorm everp	7 736 603 338							
1	Kesselbl GB125-3 Gld everp V3	7 736 616 420			■				
1	Kesselblock GB125-4 Gld everp V2	7 747 030 525				■			
1	Kesselblock GB125-2 Gld everp	8 718 588 590	■	■					
1	Kesselblock 5Gld everp	8 738 803 097					■		
2	Vorderglied 17-34 everp	8 718 585 129	■	■	■	■	■		
3	Blindstopfen G 1 1/4" re everp	8 718 571 258 0	■	■	■	■	■		
4	Dichtung D41,7x55x1,5 AFM 34 everp	8 738 807 916	■	■	■	■	■		
6	Mittelglied 17-34 everp	8 718 585 130	■	■	■	■	■		
7	Kesselnippel 48/38 Gr.0a everp	7 747 024 961	■	■	■	■	■		
8	Dichtmasse Leinölgraphit 450g Dose everp	8 718 571 927	■	■	■	■	■		
9	Haftgrund Teroson 1624-24 everp	8 718 576 019 0	■	■	■	■	■		
10	Dichtschnur D15x4300 Pack A serie/everp	8 718 584 415	■	■	■	■	■		
11	Hinterglied 17-34kW	8 718 584 710	■	■	■	■	■		
12	Stopfen G 1 everp	8 718 584 633	■	■	■	■	■		
13	Gewindestange M10x205 everp	7 747 007 599	■	■	■	■	■		
14	Dichtung D33x44x2 grafitiert everp	8 718 584 676	■	■	■	■	■		
15	Kessel-/STB-FühlerG1/4 45lg everp	6 302 487 7					■		
15	Fühler Kessel G1/4 75lg everp	6 302 964 1	■	■	■	■			
16	Ankerstange Satz M8x310 mit Kopf everp	5 127 574			■				
16	Ankerstange Satz M8x440 mit Kopf everp	5 127 578				■			
16	Ankerstange Satz M8x555 mit Kopf everp	5 127 580					■		
16	Ankerstangensatz M8x690 kpl everp	7 736 603 339						■	
16	Ankerstange Satz M8x190 mit Kopf everp	8 718 588 591	■	■					
17	Einspeisestück G 1 1/4 18-22KW everp	8 718 585 761	■	■					
17	Einspeisestück G 1 1/4 30-35kW everp	8 718 585 765			■	■			
17	Einspeisestück 5Gld everp	8 738 803 103					■	■	
18	O-Ring 44x3 Set (5x) everp	8 718 575 527 0	■	■	■	■	■		
19	Heizgaslenkplatte unten GB125 6Gld everp	7 736 603 340						■	
19	Heizgaslenkplatte 21kW/3GL m.Hebel everp	8 718 570 839 0			■				
19	Heizgaslenkplatte 28/4Gld everp	8 718 570 841 0				■			
19	Heizgaslenkplatte 40/5 Gld everp	8 718 570 842 0					■		
19	Heizgaslenkplatte 2 Gld mit Hebel everp	8 718 588 592	■	■					
20	Winkelprofilschiene GB125 6Gld everp	7 736 603 342						■	
20	Winkel Profilschiene 3Gld everp	7 747 000 018	■	■					
20	Winkelprofilschiene everp	7 747 000 019			■				
20	Winkelprofilschiene everp	7 747 000 020				■	■		
21	Scharnierwinkel everp	8 718 570 845 0	■	■	■	■	■		
22	Kesselfuß everp	8 718 584 682	■	■	■	■			
23	Gerätefuß M10x51 everp (4x)	6 302 865 7	■	■	■	■	■		
24	Heizgaslenkplatte oben GB125 6Gld everp	7 736 603 341						■	
24	Heizgaslenkplatte RLU everp	8 718 573 738 0			■				
24	Heizgaslenkplatte 5Gld RLU everp	8 718 584 681					■		
24	Heizgaslenkplatte 2 Gld. everp	8 718 588 593	■	■					

GB125 18-60kW V4

Kesselblock
Boiler block
Corps de chauffe

1

Ersatzteilliste
Spare parts list

Liste des pièces de rechange

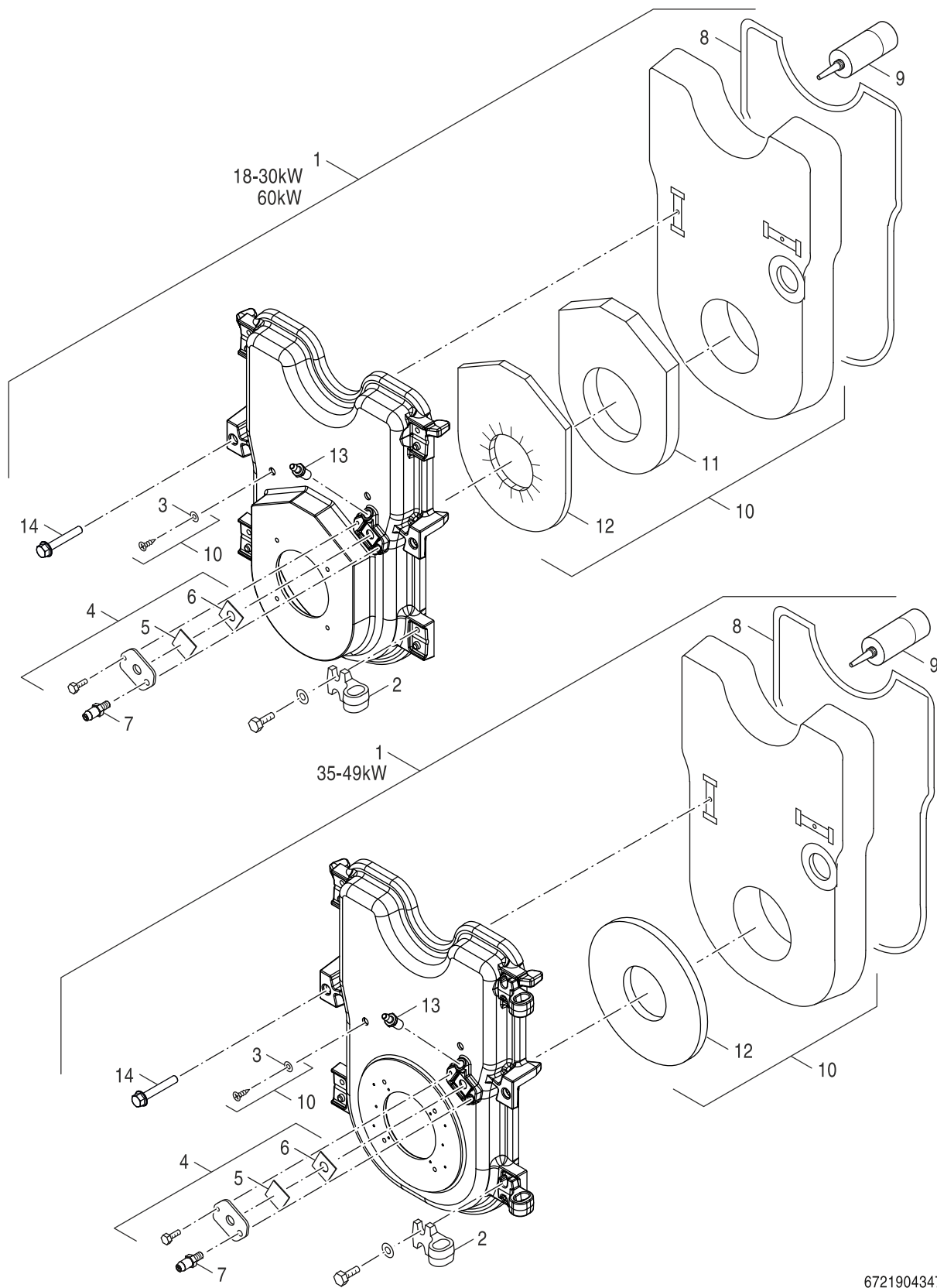

6721904347.ab.RO

2

Brennertür
Door
Porte

GB125 18-60kW V4

Ersatzteilliste
Spare parts list

Liste des pièces de rechange

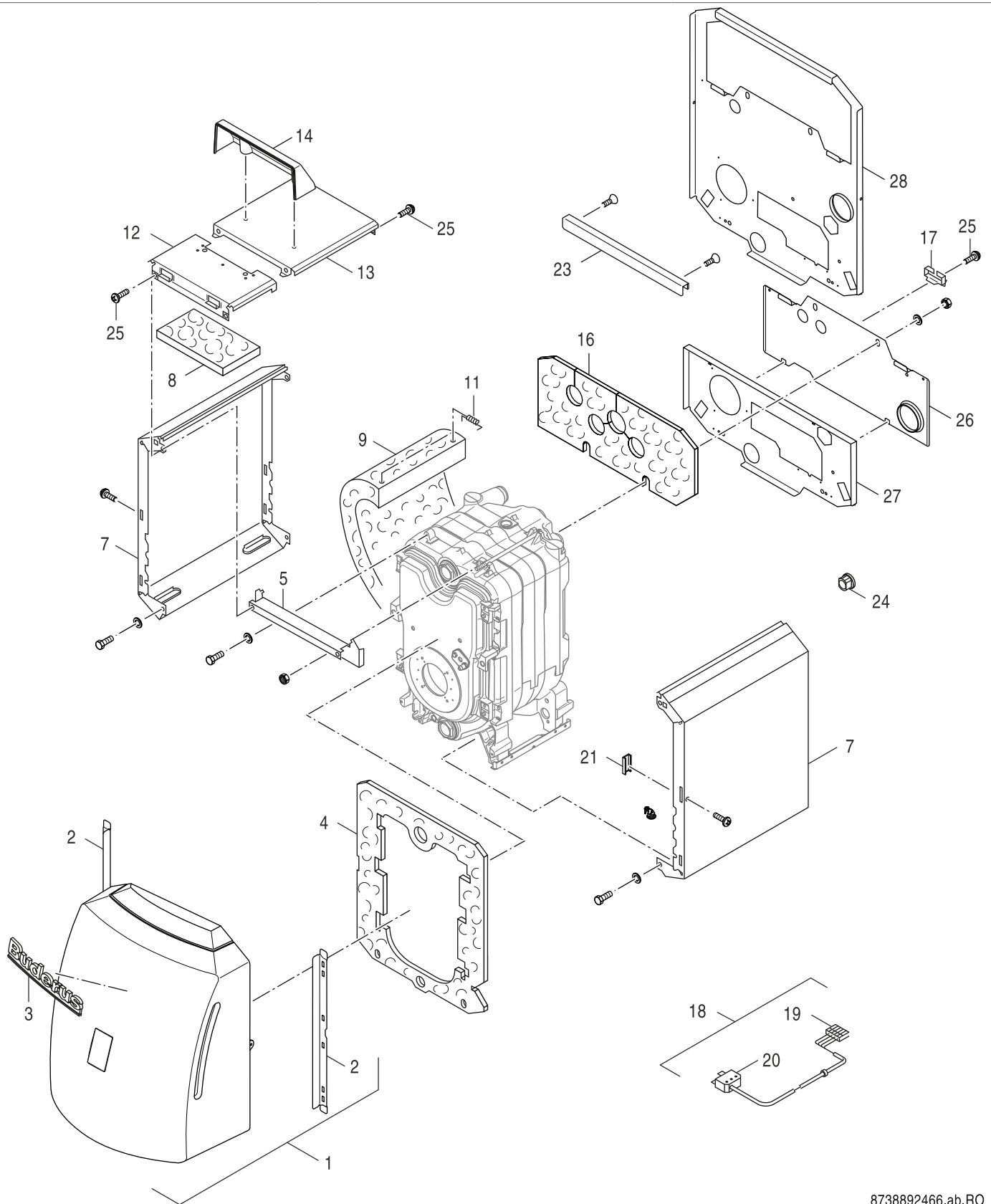

8738892466.ab.RO

Verkleidung GB125 V3
Casing GB125 V3
Habillage GB125 V3

GB125 18-60kW V4

3

Pos	Bezeichnung Description Dénomination								Bemerkungen Remarks Remarques
			GB125 18/2	GB125 22/2	GB125 30/3	GB125 35/4	GB125 49/5	GB125 60/6	
1	Brennerhaube GB125 everp	8 718 573 812 0	■	■	■	■	■		
2	Winkel seitlich everp	8 718 584 013	■	■	■	■	■		
3	Logo Buderus 186mm everp	8 718 586 514	■	■	■	■	■		
4	Wärmeschutz vorn everp	6 302 526 5	■	■	■	■	■		
5	Traverse 1,25x108x537	6 302 920 9	■	■	■				
5	Traverse 5Gld everp	8 738 803 102				■	■		
7	Seitenwand G125 3Gld kpl everp	6 302 994 5	■	■					
7	Seitenwand G125/G134 4Gld kpl everp	6 302 994 6			■				
7	Seitenwand G125 5Gld kpl everp	6 302 994 7				■			
7	Seitenwand 6 Gld blau everp	7 736 603 345					■		
7	Seitenwand 5Gld Ersatz	8 738 803 099					■		
8	Wärmeschutz 18-35KW oben everp	8 718 583 550	■	■	■	■	■		
9	Wärmeschutz Kesselblock GB125-6Gld everp	7 736 603 335					■		
9	Wärmeschutz Kesselblock 3Gld everp	8 718 585 086			■				
9	Wärmeschutz Kesselblock 4Gld everp	8 718 585 087				■			
9	Isolierung Kesselblock GB125 -2Gld everp	8 718 588 596	■	■					
9	Wärmeschutz Kesselblock 5Gld everp	8 738 803 105					■		
11	Haltefeder (10x) everp	7 747 016 084	■	■	■	■	■		
12	Haube vorn G125 kompl	6 302 994 8	■	■	■	■			
12	Haube vorne 5Gld everp	8 738 803 100					■	■	
13	Haube hi G125 3Gld kpl everp	6 302 994 9	■	■					
13	Haube hi G125 4Gld everp	6 302 995 0			■				
13	Haube hi G125 5Gld everp	6 302 995 1				■			
13	Haube hinten 6 Gld blau everp	7 736 603 346					■		
13	Haube hinten 5Gld everp	8 738 803 101					■		
14	Anschlusshaube blau everp	6 302 626 1			■				
16	Wärmeschutz Rückwand everp	8 718 585 083	■	■	■	■	■		
17	Kabelhalter (5x) everp	8 718 584 331	■	■	■	■	■		
18	Brennerleitung 2350 1-Stufe everp	7 747 007 984	■	■	■	■			
19	Anschlussklemme 7-polig BR I grün everp	7 747 023 989	■	■	■	■			
20	Steckerteil ST18/7 versilbert everp	6 790 316 4	■	■	■	■			
21	Kantenschutz Set 65+80+160lg everp	6 302 089 6	■	■	■	■	■		
23	Winkel Rückwand V3 everp	8 718 588 405	■	■	■				
24	Kabeldurchführung everp	8 718 583 548	■	■	■	■	■		
25	Flachkopfschraube ST3,9x9,5 A3T (10x)	7 747 026 999	■	■	■	■	■		
26	Rückwand oben V2 everp	8 718 588 594	■	■	■				
27	Rückwand unten V4 everp	8 718 588 595	■	■	■				
28	Rückwand 5Gld everp	8 738 803 104					■	■	

GB125 18-60kW V4

Verkleidung GB125 V3
Casing GB125 V3
Habillage GB125 V3

3

Ersatzteilliste
Spare parts list

Liste des pièces de rechange

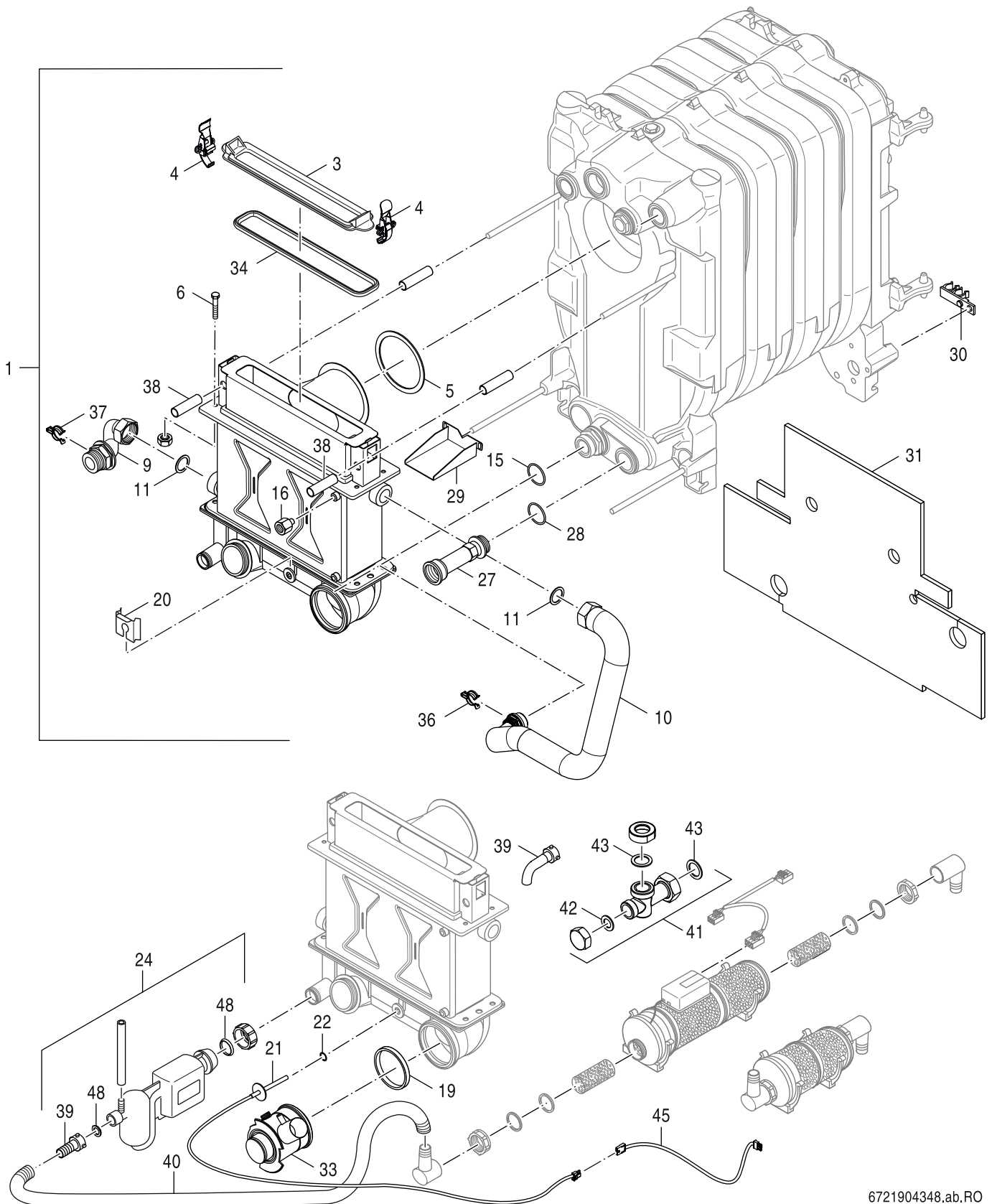

6721904348.ab.RO

Wärmetauscher
Heat exchanger
Échangeur thermique

GB125 18-60kW V4

4

Pos	Bezeichnung Description Dénomination								Bemerkungen Remarks Remarques
			GB125 18/2	GB125 22/2	GB125 30/3	GB125 35/4	GB125 49/5	GB125 60/6	
1	WT-System 30-60 V2 everp	8 718 585 125			■	■	■		
1	WT-System 18-22 V2 everp	8 718 585 126	■	■					
3	Deckel Abgasv 18-22 Al kpl V3 everp	8 738 806 338	■	■					mit eingeklebter Dichtung
3	Deckel Abgasv 30-60 Al kpl V2 everp	8 738 806 339			■	■	■		mit eingeklebter Dichtung
4	Schnellverschluss	7 098 848	■	■	■	■	■		
5	Dichtung Fasermat Hgl-Abgasvert everp	8 718 581 466	■	■	■	■	■		
6	Schrauben-Set everp	8 718 585 089	■	■	■	■	■		
9	Rücklauf Rohr HK/WT G1 V3 everp	8 718 588 597	■	■					
9	Rücklauf-Rohr HK/WT G1 1/4 V3 everp	8 718 588 598			■	■	■		
10	Rücklauf-Rohr RK/WT G1 everp V2	7 747 030 541	■	■					
10	Rücklauf-Rohr RK/WT G 11/4 V2 everp	8 718 571 053 0			■	■	■		
11	Dichtung D21X30X3, DVGW-zugel.(5x) everp	8 718 584 714	■	■	■	■	■		
15	O-Ring 21,89x2,62 70EPDM everp (5Stk)	8 718 570 357 0	■	■					
15	O-Ring 28x3 70EPDM/281 everp 5Stk	8 718 571 057 0			■	■	■		
16	Entlüfter 1/8 BSP	8 716 140 238 0	■	■	■	■	■		
19	Lippendichtung DN80	8 737 711 685	■	■	■	■	■		
20	Fühlerhalterung (2x) everp	8 718 585 548	■	■	■	■	■		
21	Abgasfühler D29/d6 60mm everp	7 747 002 902	■	■	■	■	■		
22	O-Ring 6x2 ISO 3601 FKM (3x) everp	7 747 007 462	■	■	■	■	■		
24	Siphon-Set V4 everp	8 738 806 366	■	■	■	■	■		FD>06.2018
27	Verlängerung G1x120 V2 everp	8 718 585 117	■	■	■	■	■		
28	O-Ring 35x3 Set (5x) everp	8 718 575 526 0	■	■	■	■	■		
29	Halter Siphon GB125 V4 everp	8 718 588 600	■	■	■	■	■		
30	Leitungshalter everp	8 718 585 071	■	■	■	■	■		
31	Wärmeschutz WT 18-22 kW everp	8 718 585 084	■	■					
31	Wärmeschutz WT 30-35 kW everp	8 718 585 085			■	■	■		
33	KAS konzentrisch für GB125, Ø80/125	7 738 113 263	■	■	■	■	■		60kW-Nur Innenrohr nutzen
34	Dichtung Abgasv 30-35 Al V2 everp	8 718 579 535			■	■	■		
34	Dichtung Abgasvert 18-22KW AL everp	8 718 585 764	■	■					
36	Federclip d=32,6/22 everp (5Stk)	7 747 030 542	■	■					
36	Federclip d=38,2/28 everp 5Stk	8 718 571 056 0			■	■	■		
37	Federstecker D26 everp	7 747 030 559	■	■	■	■	■		
38	Isolierung Gewindestange 36,2 everp	7 747 015 461			■	■	■		
38	Distanzhülse 17,2x2,1x63,5 everp	8 718 590 261	■	■					
39	Verschraubung 2/3 R3/4 everp	7 747 021 911	■	■	■	■	■		
39	Schlauchtülle G3/4x20 gewinkelt everp	8 738 803 123	■	■	■	■	■		alternativ
40	Schlauch-Set DN20 (3m) verp	7 747 007 644	■	■	■	■	■		Zubehör
41	T-Stück kpl everp	5 584 368	■	■	■	■			
41	T-Stück 60 kW everp	8 738 805 365					■		
42	Dichtung D18x30x2 EPDM everp	8 718 585 262	■	■	■	■	■		
43	Dichtung D27x38x2 DVGW-zugelassen everp	8 718 584 801	■	■	■	■	■		
45	Leitung Verlängerung Abgasfühler 330 eve	8 732 919 259					■		
48	Dichtungs-Set Siphon everp	7 747 016 504	■	■	■	■	■		

GB125 18-60kW V4

Wärmetauscher
Heat exchanger
Échangeur thermique

4

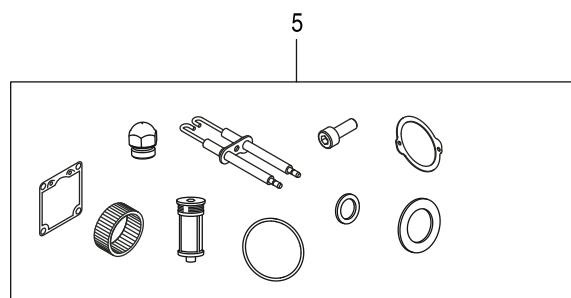
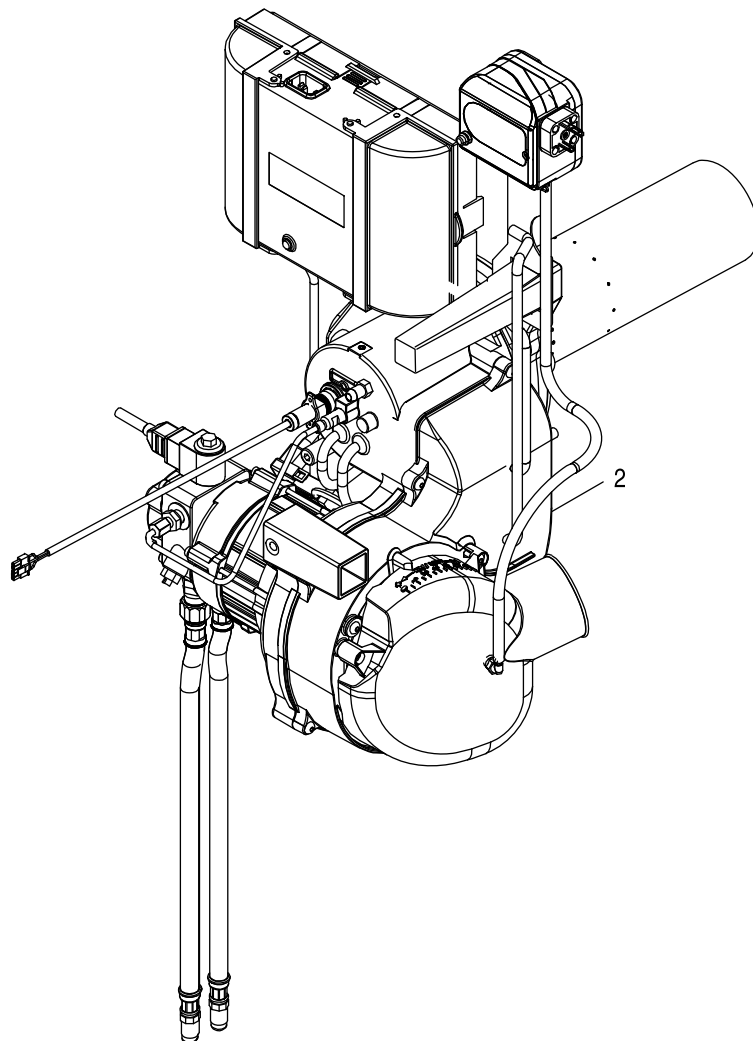

6721904349.aa.RO

5
Brennervarianten
Burner versions
Variantes de brûleur

GB125 18-60kW V4

Pos	Bezeichnung Description Dénomination																				Bemerkungen Remarks Remarques
2	Ölbrenner BE 2.3-60 K RLA everp	7 736 603 347																			
2	Ölbrenner BE 1.3-18 kpl V3 everp	8 738 806 297	■																		
2	Ölbrenner BE 1.3-22 kpl V3 everp	8 738 806 298		■																	
2	Ölbrenner BE 2.3-30 kpl V3 everp	8 738 806 299			■																
2	Ölbrenner BE 2.3-35 kpl V3 everp	8 738 806 300				■															
2	Ölbrenner BE 2.3-49 kpl V3 everp	8 738 806 301					■														
5	Service-Set BE 18kW everp	7 736 604 320	■																		
5	Service-Set BE 22kW everp	7 736 604 321		■																	
5	Service-Set BE 30kW everp	7 736 604 322			■																
5	Service-Set BE 35kW everp	7 736 604 323				■															
5	Service-Set BE 49kW everp	7 736 604 324					■														
5	Service-Set BE 60kW everp	7 736 604 325						■													

GB125 18-60kW V4

Brennervarianten
Burner versions
Variantes de brûleur

5

Ersatzteilliste
Spare parts list

Liste des pièces de rechange

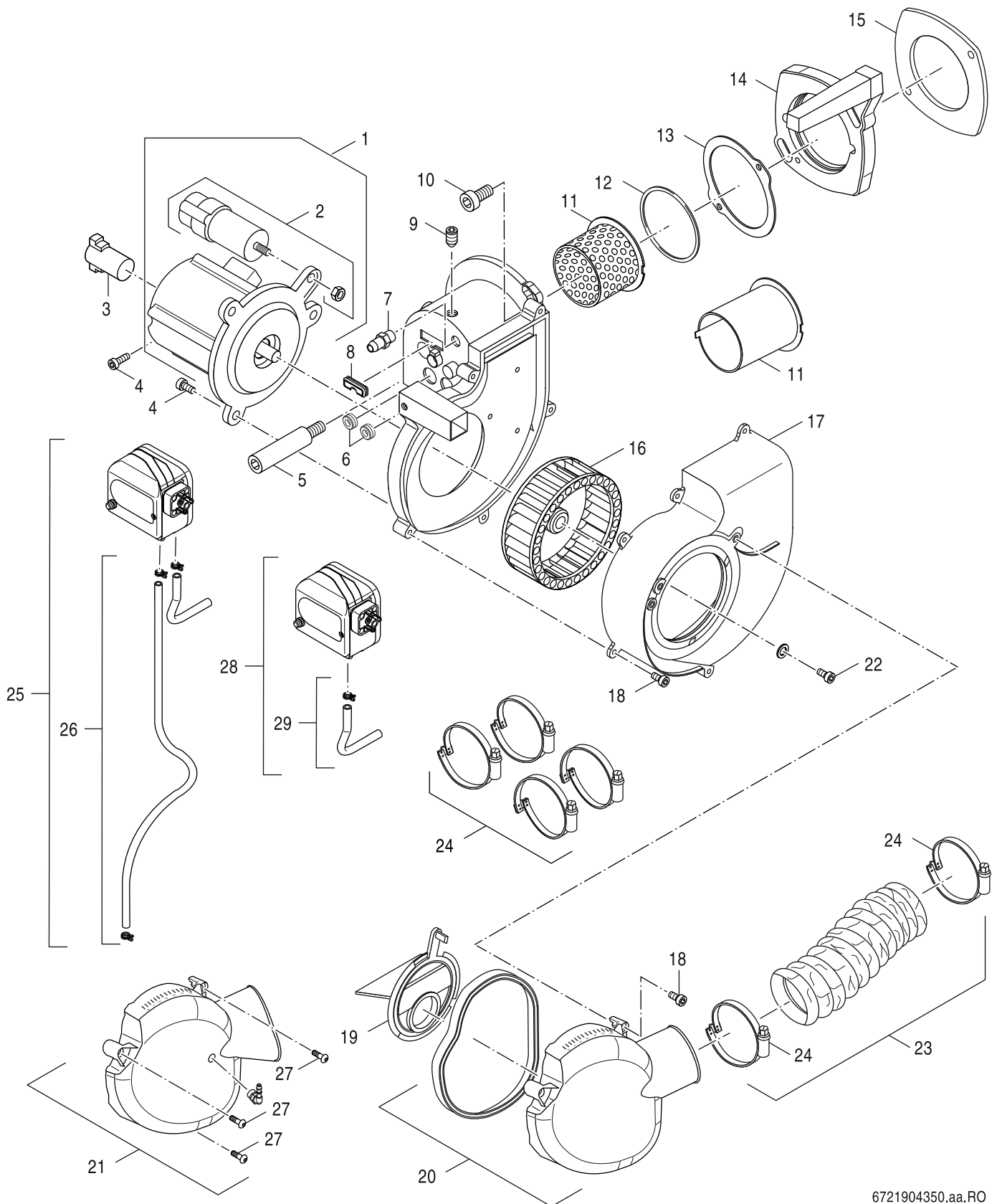

6721904350.aa.RO

Brennergehäuse
Burner housing
Lgement de brûleur

GB125 18-60kW V4

6

Ersatzteilliste
Spare parts list

Liste des pièces de rechange

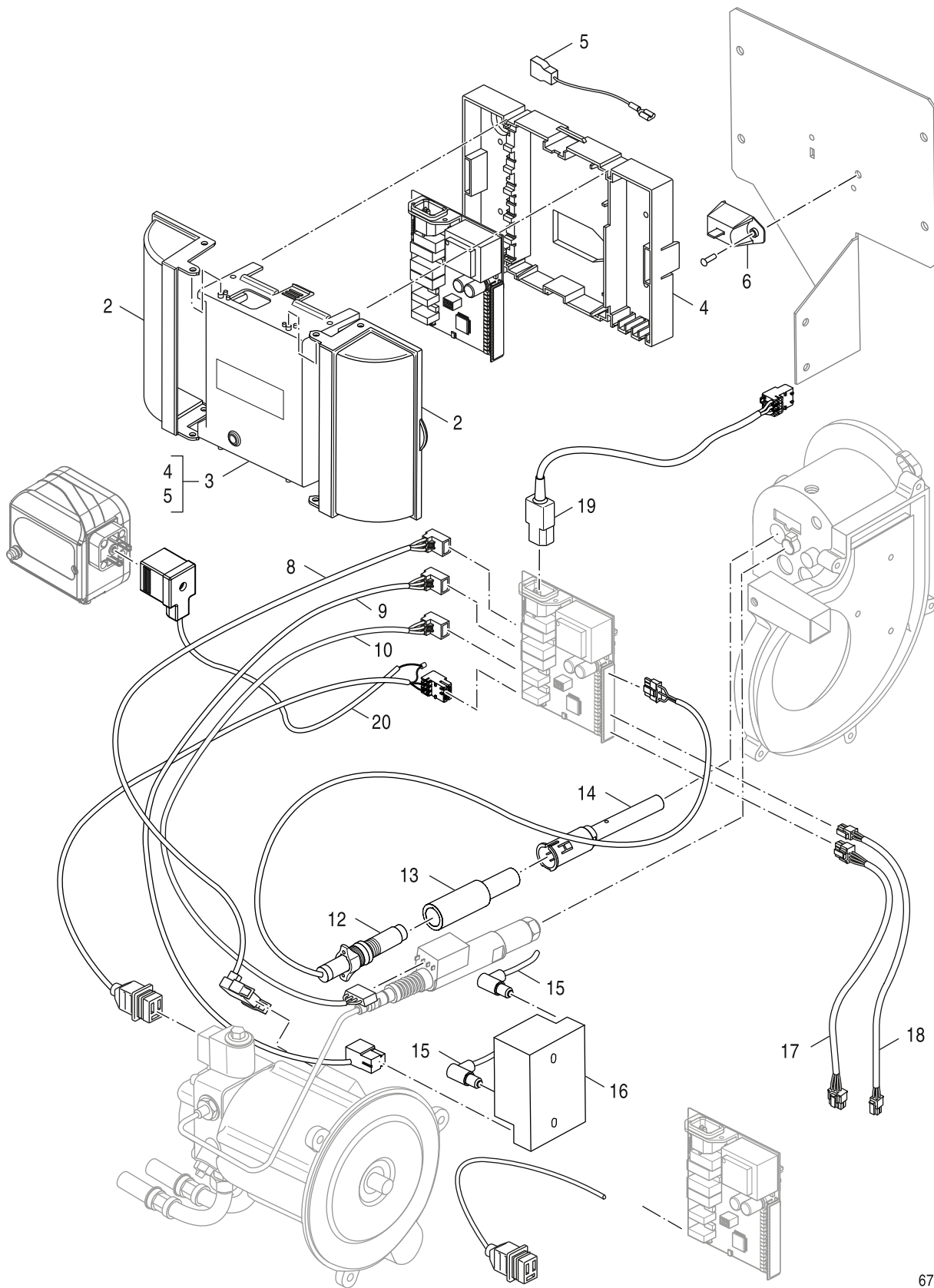

6721904351.aa.RO

7 Brennersteuerung
control unit
Commande

GB125 18-60kW V4

Pos	Bezeichnung Description Dénomination								Bemerkungen Remarks Remarques
			GB125 18/2	GB125 22/2	GB125 30/3	GB125 35/4	GB125 49/5	GB125 60/6	
2	Gehäuse Klemmenabdeckung SAFe everp	6 302 392 5	■	■	■	■	■		
3	SAFe30 V7 DNA everp	8 732 936 996	■	■	■	■	■		
4	Gehäuse Unterteil SAFe everp	6 302 393 0	■	■	■	■	■		
5	Adapter H05V-K 0,75 0,8/2,0 gn/ge verp	6 303 350 7	■	■	■	■	■		
6	Modul BIM30 V10 GB125-60 everp	8 732 919 565					■	Nur für Service-Techniker	
6	Modul BIM30*-LoI/01 V10 18-49 everp	8 738 806 346	■	■	■	■		Nur für Service-Techniker	
8	Verbindungsleitung SAFe-Motor BE everp	6 303 014 8	■	■	■	■			
8	Verbindungsleitung Motor 380 everp	8 732 912 559					■		
9	Verbindungsleitung Zündung 410 everp	8 732 912 561					■		
9	Zündleitung SAFe 230V everp	8 738 802 738	■	■	■	■			
10	Verbindungsleitung Ölvorw SAFe BE everp	6 303 014 9	■	■	■	■			
10	Verbindungsleitung Ölvorwärmer 375 everp	8 732 912 562					■		
12	UV-Flammenfühler QRC SAFe BZ/BE_3everp	6 303 396 5	■	■	■	■	■		
13	Halterohrverlängerung BE_3 RLU V2	7 747 001 399	■	■	■	■	■		
14	Halterohr HG V4 everp	8 718 585 517	■	■	■	■	■		
15	Zündleitung BE/BE-A everp	6 300 689 0	■	■	■	■			
15	Zündleitung Reakt. 1550 Ohm 275mm everp	8 732 919 563					■		
16	Zündeinrichtung Danfoss EBI V4 everp	8 718 575 099 0	■	■	■	■	■		
17	Datenleitung SAFe MC10 BE everp	6 303 015 0	■	■	■	■	■		
18	Verbindungsleitung Kesselfühler SAFe BE	6 303 921 4	■	■	■	■			
18	Verbindungsleitg Kesselfüh SAFe 1900 everp	8 732 912 855					■		
19	Verbindungsleitung SAFe Netz 1250 everp	8 732 912 558	■	■	■	■	■		
20	Verbindungsleit MV 1 Druck 320/580 everp	8 732 912 560	■	■	■	■	■		

GB125 18-60kW V4

Brennersteuerung
control unit
Commande

Ersatzteilliste
Spare parts list

Liste des pièces de rechange

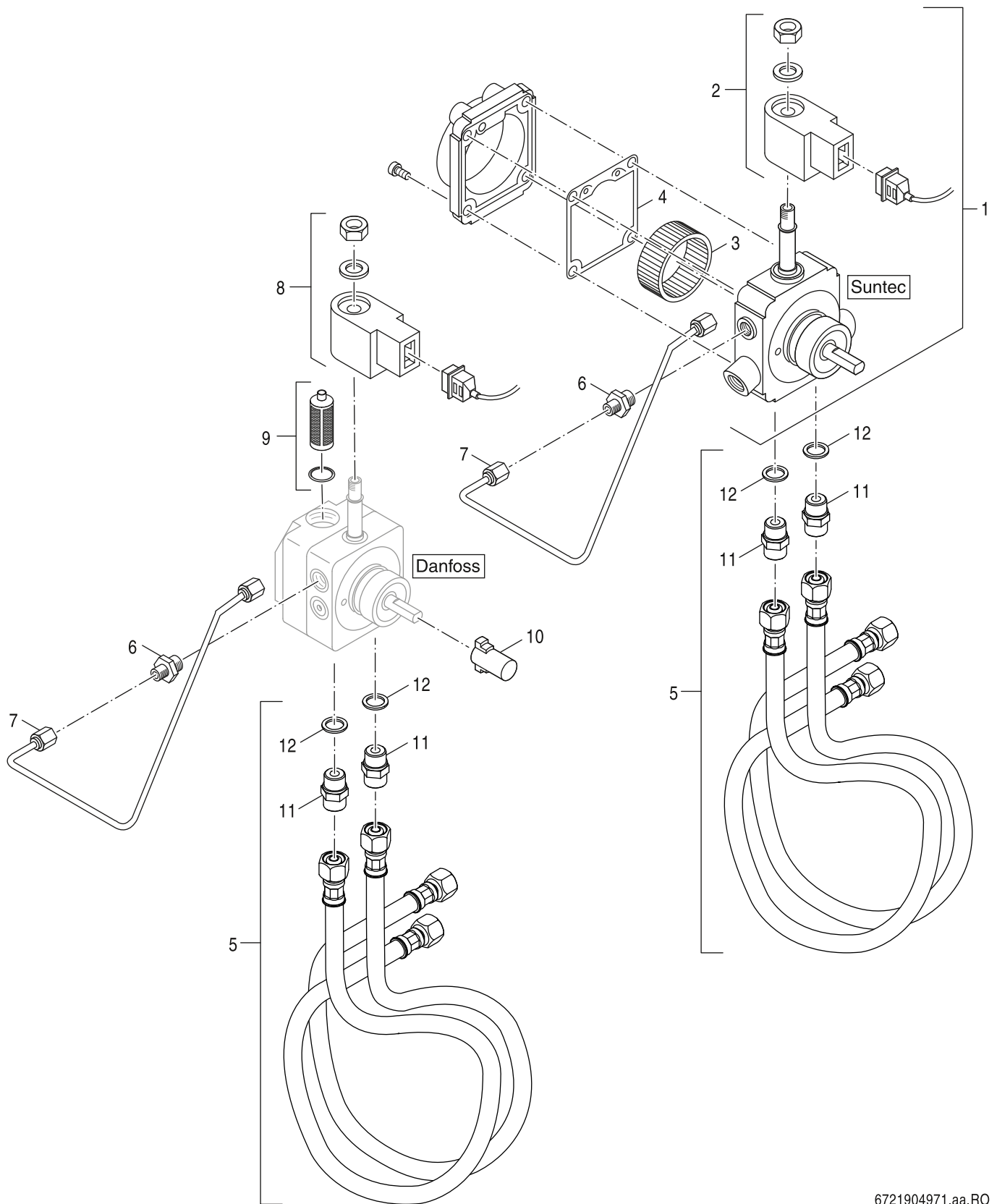

6721904971.aa.RO

8B
Ölpumpe
oil pump
Pompe à fioul

GB125 18-60kW V4

Pos	Bezeichnung Description Dénomination								Bemerkungen Remarks Remarques
			GB125 18/2	GB125 22/2	GB125 30/3	GB125 35/4	GB125 49/5	GB125 60/6	
1	Ölpumpe Suntec ALEV35C everp	8 718 578 019	■	■	■				
1	Ölpumpe Suntec ALEV55C everp	8 718 578 021				■	■	■	
2	Magnetspule Suntec220-240V/50-60Hz everp	7 747 021 595	■	■	■	■	■		
3	Filter Ölpumpe A70 Rev.3 AS47 (2x)	8 718 572 496 0	■	■	■	■	■		
4	Dichtung Ölpumpe ALE35/55 (2x) everp	8 718 572 498 0	■	■	■	■	■		
5	Schlauchset BE/RE	6 301 424 1	■	■	■	■	■		
6	Einschraubverschr GE 4LLR 1/8"Zyl everp	8 718 592 457	■	■	■	■	■		
7	Ölrohr HG-A kpl everp	8 718 584 674	■	■	■	■	■		
8	Magnetspule BFP 21/31 L3 everp	8 718 572 501 0	■	■	■	■	■		
9	Filter Ölpumpe BFP 21/31 L3 (2x)	8 718 572 503 0	■	■	■	■	■		
10	Kupplung weiß (2x) 2-flächig	8 718 572 841 0	■	■	■	■	■		
11	Verschraubung G3/8" x G1/4" gerade everp	8 718 584 651	■	■	■	■	■		
12	Dichtring 13x18x1,5 (5x) everp	8 718 584 808	■	■	■	■	■		

GB125 18-60kW V4

Ölpumpe
oil pump
Pompe à fioul

8B

Ersatzteilliste
Spare parts list

Liste des pièces de rechange

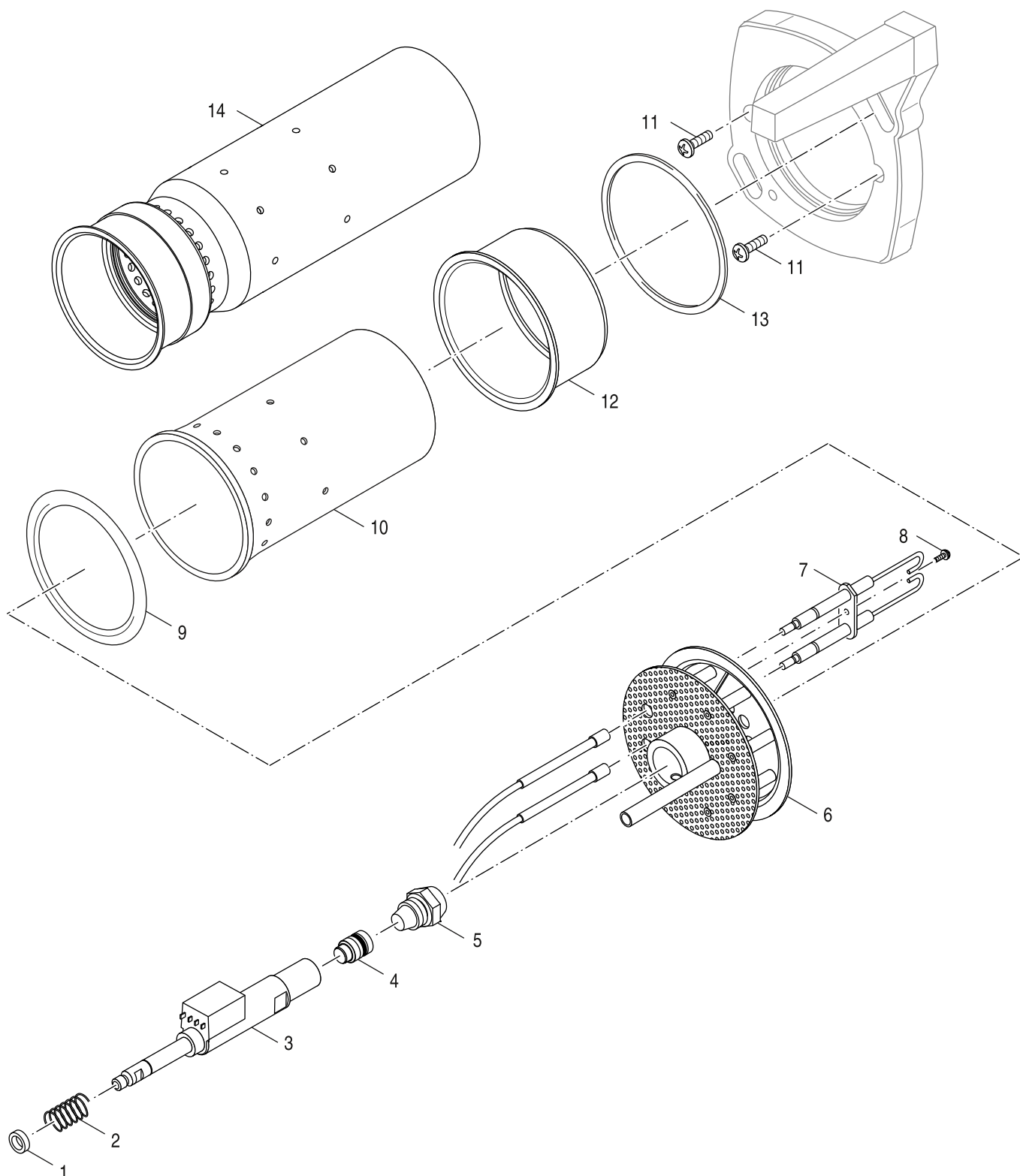

6721904352.aa.RO

9A Mischeinrichtung
mixer Suntec
Chambre de melange Suntec

GB125 18-60kW V4

Pos	Bezeichnung Description Dénomination								Bemerkungen Remarks Remarques
			GB125 18/2	GB125 22/2	GB125 30/3	GB125 35/4	GB125 49/5	GB125 60/6	
1	Scheibe D9,5/14x4 Ver02 everp	8 718 584 673	■	■	■	■	■		
2	Druckfeder DIN2098 1,8x12,5x36 everp	7 747 012 279	■	■	■	■	■		
3	Ölvorwärmer FPHE-LE 030N5129 PTC50 everp	8 718 578 602	■	■					
3	Ölvorwärmer FPHB5-LE PTC70 B10 everp	8 718 578 603			■	■	■		
4	Abschlussventil LE6 everp	6 302 512 6	■	■	■	■	■		
5	Öldüse 0,55gph 60Gr HR Danfoss everp	7 736 604 063		■					
5	Öldüse 1,00gph 60Gr H Danfoss everp	7 747 028 942					■		
5	Öldüse 0,45gph 80Gr HFD Danfoss everp	7 747 028 943		■					
5	Öldüse 0,85gph 60Gr H everp	7 747 028 962				■			
5	Öldüse 0,35gph 80Gr HR everp (1x)	7 747 028 974	■						
5	Öldüse 0,45gph 80Gr HFD Danfoss (12x)	7 747 028 988		■					
5	Öldüse 0,35gph 80Gr HR Danfoss (10x)	7 747 028 991	■						
5	Öldüse 0,65gph 80° everp	8 718 572 504 0			■				
5	Öldüse 0,55gph 60Gr HR Danfoss 10 Pack	8 738 807 238		■					
6	Mischsystem BE 12,0/25,0/5,0/25 everp	7 747 002 844	■						
6	Mischsystem BE 12,1/27,5/5,8/25 everp	7 747 002 845		■					
6	Mischsystem BE 12,1/27,5/6,9/25 VA everp	7 747 002 846			■				
6	Mischsystem BE 12,4/27,5/8,3/25 VA everp	7 747 002 847				■			
6	Mischsystem BBE/BE-A 2.1-43/45kW everp	8 718 585 041					■		
6	Mischsystem BE 55kW everp	8 718 585 042					■		
7	Zünderlektrode BE/BE-A Typ4 L34 everp	8 718 585 036	■	■	■	■			
7	Zünderlektrode BE Typ4 L50 V2 everp	8 718 585 045					■		
7	Zünderlektrode BE T4 L 58,5 V2 everp	8 718 585 046					■		
8	Zylinderschraube DIN912 M4x10 (5x)everp	7 747 029 972	■	■	■	■	■		
9	Dichtung D75,5 V2 everp	6 303 793 0					■		
9	Dichtung D81 V2 everp	8 718 585 504	■	■	■	■	■		
10	Brennerrohr D69/L214 SiC 18kW everp	6 302 260 4	■						
10	Brennerrohr D83/L214/3,0/2,5 SiC 25kW	6 302 260 7		■					
10	Brennerrohr D83/L224/5,9/4,8 SiC everp	6 303 072 7			■				
10	Brennerrohr D83/L224/7,0/5,7 SiC everp	6 303 072 8				■			
10	Brennerrohr D83/L224/5,7/5,4 SiC everp	6 303 072 9					■		
11	Linsenschraube ISO7380 M5x8 (5x)	7 747 029 977	■	■	■	■	■		
12	Stützrohr L50 everp	6 302 259 5	■	■	■	■	■		
13	O-Ring 92x3 Viton everp	6 300 299 8	■	■	■	■	■		
14	Brennerrohr D96/L257,5/5,5/4,9/4,9-8 eve	6 303 364 1					■		
	Mont-Mat Ölbrenner BE everp	8 718 585 037	■	■	■	■	■		

GB125 18-60kW V4

Mischeinrichtung
mixer Suntec
Chambre de melange Suntec

9A

Ersatzteilliste
Spare parts list

Liste des pièces de rechange

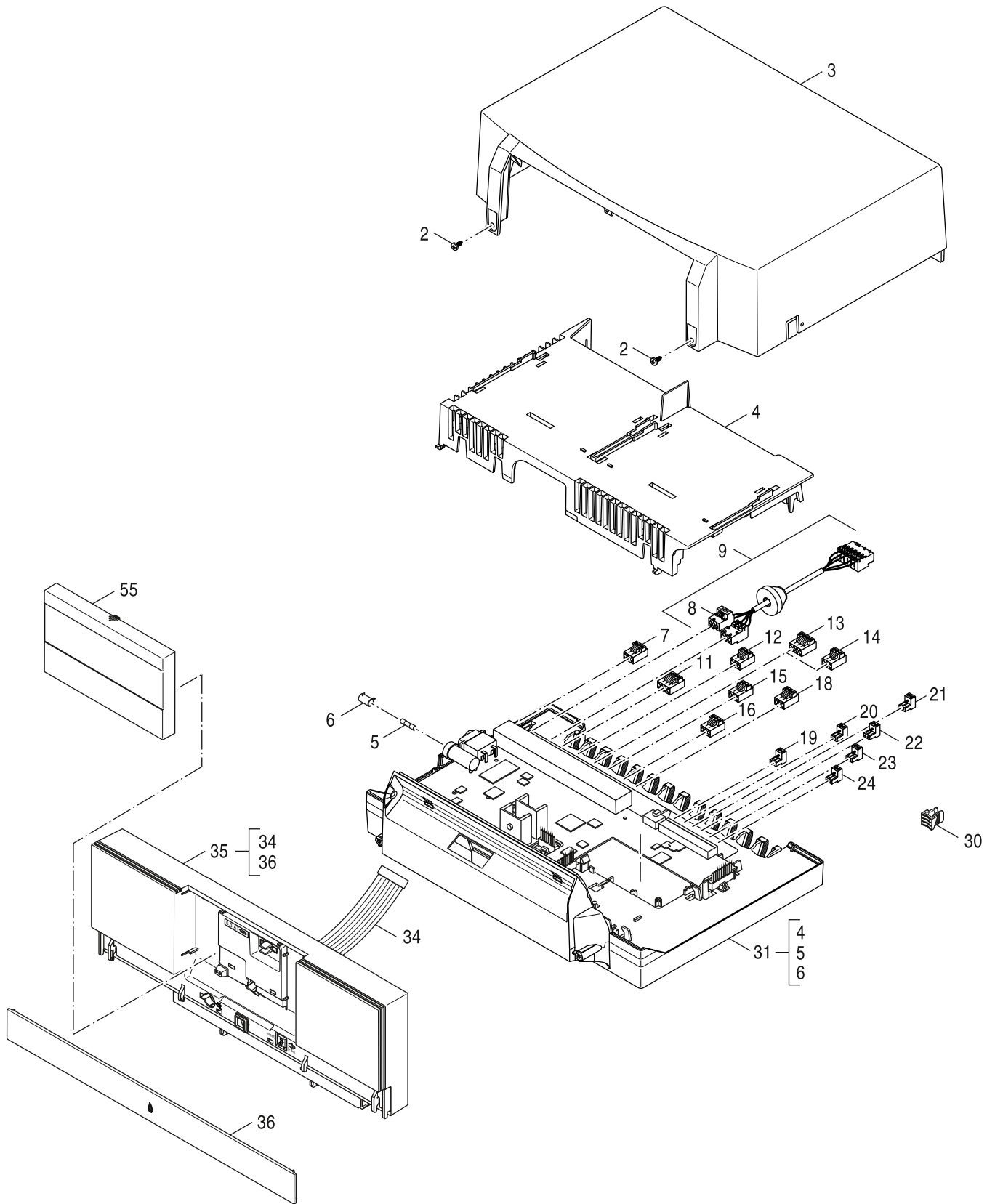

6721904597.aa.RO

GB125 18-60kW V4

9B
RMC110
RMC110
RMC110

Übersetzungsliste
List of translations

Liste des traductions

Pos	Description	Description			
1	Element of construction	Groupe d'assemblage			
1	Boiler Block 6sec mounted	Bloc chaudière 6sec			
1	boiler block GB125-3sect packed V3	bloc chaudière GB125-3 Gld V3			
1	Boiler bl GB125-4 sect everp V2 block GB	Corps de chauffe GB125-4 éléments			
1	Boiler_block GB125 2 sect packed	Corps de chauffe 2 sect			
1	Boiler block 5 sec	Bloc chaudière 5 sec			
2	Section front 17-34	Élément avant 17-34			
3	Blanking plug G 1 1/4	Raccord aveugle G 1 1/4			
4	Plug Gasket D41,7x55x1,5 AFM34 sp	Joint D41,7x55x1,5 AFM 34			
6	Section middle 17-34	Élément intermédiaire 17-34			
7	Boiler fitting 48/38 Sz 0a repl. pack	Nipple de chaudiere 48/38 T.0A			
8	Sealant linseed oil graphit 450g box sp	Minium boite 450g			
9	Primer Teroson 1624-24	Apprêt Teroson 1624-24			
10	Rope seal D15x4300 Pack A	Cordon étanch. D15x4300 Pack A 2 RLX			
11	Rear_section 17-34kW	Elément arrière 17-34 kW			
12	Plug G 1	BOUCHON G1			
13	Grub screw M10x205 replacem pack	Barre fileté M10x205			
14	Gasket D33x44x2mm	Joint D33x44x2mm			
15	Sensor boiler G1/4 45mm sp	Sonde chaudiere g1/4 45mm			
15	Sensor boiler G1/4 75lg	Sonde chaudiere g1/4 75lg			
16	Tie rod kit M8x310mm	JEU TIGE D'ANCRAGE M8x310mm			
16	Tie rod kit M8x440mm	Jeu tige d'ancrage M8x440mm			
16	Tie rod kit M8x555mm	Jeu tige d'ancrage M8x555mm			
16	Tie rod set M8x690 cpl	Tige de vis Set			
16	Tie_rod M8x190 with head packed	Tige de vis Set M8x190			
17	Feed unit G 1 1/4 18-22KW everp	Tuyau d'alimentation G1 1/4 18-22kW			
17	Feed unit G 1 1/4 30-35kW everp	Tuyau d'alimentation G1 1/4 30-35kW			
17	Feed unit 5 sect	Tuyau d'alimentation 5 sect			
18	O-ring 26x3 Set (5x)	JOINT TORIQUE 44x3 (5 X)			
19	Baffle GB125 6sec lower	Turbulateur 6sec bas			
19	Plate Hot gas baffle	Turbulateur			
19	Baffle hot gas -2 sect w. lever	Turbulateur			

Übersetzungsliste
List of translations

Liste des traductions

Pos	Description	Description			
20	Guide Rail Profile GB125 6sec	Rail 6sec			
20	Angle profile rail 3sect everp	Angle pour profilé 3 éléments			
20	Angle profile rail 4sect everp	RAIL PROFIL EN EQUERRE ELMT			
20	Angle profile rail 5sect everp	Rail profilé en équerre			
21	Hinge bracket	Charnière Equerre			
22	Stand boiler	Pied de la chaudière			
23	Foot M10x51 (4x)	Pieds réglables M10x51 (4x)			
24	Baffle GB125 6sec upper	Turbulateur haut			
24	Baffle hot gas RLU [63028998]	TURBULATEUR RLU [63028998]			
24	Plate hot gaz baffle 5 Sections RLU	Turbulateur 5sec RLU			
24	Baffle hot gas 2 sect. packed	Turbulateur			
2	Element of construction	Groupe d'assemblage			
1	Burner door GB 60 DE	Porte V2			
1	Burner door GB 18-30 BE sp	porte du brûleur GB 18-30 BE			
1	Burner door GB 35-49 BE sp	porte du brûleur GB 35-49 BE			
2	Hinge painted	Charnière			
3	Cover DIN9021 A6,4 A3K packed	Rondelle DIN9021 A6,4 A3K (1x)			
4	Viewing hole lock V3 compl.	Viseur flam v3			
5	Glass pane 30x30x3,3mm repl pack	Verre tempax 30x30x3,3mm v2			
6	Gasket 30x30x3mm	Joint 30x30x3 (G315)			
7	Measuring nozz M6 SW10 V2	Injecteur de mesure de press. M6 SW10 V2			
8	Packing cords GP14x1650mm long	Cordon d'étanchéité gp 14x1650 long			
9	Sealant brown 310ml	Cartouche mastic pressurisé 310			
10	Insulation burner door GB125/60	Insulation burner door GB125/60			
10	Insulation burner door GB125 18-30 BE sp	Isolation GB125 18-30 BE			
10	Insulation burner door GB125 35-49 BE sp	Isolation GB125 35-49 BE			
11	Insulation for burner door G/ GB125 sp	Isol porte brûl G/GB125			
12	Insulation ring burn-door GB125 35-49 sp	Isolation GB125 35-49 BE			
12	Insulation ring burn-door GB125 sp	Isolation GB125			
13	Screw in socket D6 G1/8" SW17	Buse D6 G1/8"			
14	Screw kit DIN6921 M10x65 8.8 SW16	Jeu des vis DIN6921 M10x65 8.8 SW16			
3	Element of construction	Groupe d'assemblage			

Übersetzungsliste
List of translations

Liste des traductions

Pos	Description	Description			
1	Burner hood GB125	Capot bruleur GB125			
2	Angle lateral (2 Pieces) everp	Équerre partie			
3	Badge Buderus 186mm	Logo Buderus 186mm			
4	Thermal insulation front 12x580x695	Isol av			
5	Tie-bar 1,25x108x537	HABIL TRAVERSE			
5	tie bar 5 sect	Traverse 5 sect			
7	Side panel 445mm long G125	Habil lat G115/125 3 elm			
7	Side panel 565mm long G125	Habil lat.G115/G125/G134 4 elm			
7	Side panel 685mm long G125	HABIL LAT G115/G125-5 ELM/GB125-4 ELM			
7	Penel side 6 sec blue	Face latérale 6sec			
7	Side panel 5sect repla	Face latérale 5 sect			
8	Insulation heat above everp	Isolation thermique haut			
9	Insulation termal boiler GB125-6sect	Insulation termal boiler 6sect			
9	Insulation burner block 3 sect	Isolation 3sec			
9	Insulation burner block 4 sect	Isolation 4sec			
9	Insulation boiler block GB125-2 sect	Isolation bloc chaudière GB125-2sec			
9	Thermal insul boiblk 5 sect	Isolation 5 sect			
11	Insulation Clamp (10x)	Ressorts de retenue d 0.8 (10x)			
12	Hood front G125	Habil facade G125			
12	Hood front 5 sect	Capot avant 5 sec			
13	Hood rear G125 3sect	Habil ar G125 3 elm cpl			
13	Hood rear G125 4sect	Habil ar G125 4 elm cpl			
13	Hood rear G125 5sect	HABIL AR G 125 5 ELM			
13	Hood rear 6 sec blue	Capot arrière 6sec			
13	Hood rear 5 sect	Capot arrière 5 sect			
14	Conn hood blue	Capot bleu			
16	Insulation rear panel	Isolation panneau arriere			
17	Cable clip (5x)	ATTACHE RAPIDE (5x)			
18	Burner cable 2350 1-step	Câble de brûleur 2350mm			
19	Connector 7-pole BR I green	Borne de connexion 7- pôles BR I vert			
20	Connector part ST18/7 silver-plated	Connect st18/7 argente			
21	Edge protection kit 65+80+160g	PROTECT BORDS 65/80/160			

Übersetzungsliste
List of translations

Liste des traductions

Pos	Description	Description			
23	Angle rear panel V3 packed	Équerre V3			
24	Cable penetration everp	Passe-câbles			
25	Pan-head screw ST3,9x9,5 A3T (10x)	Vis à tête plate ST3,9 (10x)			
26	Back_panel top V2 packed	Panneau arrière haut			
27	Back_panel bottom part V4 packed	Panneau arrière bas			
28	Rear panel 5 sect	Panneau arrière 5 sect			
4	Element of construction	Groupe d'assemblage			
1	Heat_exchanger sec system 30-60 V2	Échangeur thermique 30-60			
1	Heat_exchanger sec system 18-22 V2	Échangeur thermique 18-22 V2			
3	cover fluegas distrib 18-22 AL V3 sp	Couvercle collecteur de combustion 18-22			
3	Cover fluegas distrib 30-60 AL V2 sp	Couvercle collecteur de combustion 30-60			
4	Fasteners	Fixation rapide			
5	Gasket fibre section/flue gas adapter ev	Joint élément arrière			
6	Screw set	Vis-Set			
9	Return pipe HK/WT G1 V3 packed	Tube retour HK/WT G1			
9	Return pipe HK/WT G1 1/4 V3 packed	Tube retour HK/WT G1 1/4			
10	Return pipe RK/WT G1 everp V2 pipe RK/WT	Tube retour RK/WT G1			
10	Return pipe RK/WT G11/4 V2 everp	Tube retour RK/WT G1 1/4 V2			
11	Gasket D21X30X3, DVGW-ZUGEL (5x) everp	Joint D21x30x3 (5x)			
15	O-ring 21,89x2,62 70EPDM everp (5pcs)	Joint torique 21,89x2,62 70EPDM			
15	O-ring 28x3 70EPDM/281	JOINT CONDENSEUR V2 GB 125 30-35 KW			
16	Air vent 1/8 bsp	Purgeur 1/8 BSP			
19	Lip seal DN80	Joint DN80			
20	Sensor holder (2x)	FIXATION SONDE (2x)			
21	Gas sensor D29/d6 60mm	Sonde de temperature de fumee 60mm			
22	O-ring 6x2 ISO 3601 FKM (3pc)	Joint torique 6x2 ISO 3601 FKM (3x)			
24	Siphon-Set V4 sp	Siphon-Set			
27	Extension G1x120 V2	Rallonge G1x120 V2			
28	O-ring 35x3 Set (5x)	Joint torique 35x3 Set (5x)			
29	Bracket siphon GB125 V4 packed	Support Siphon V4			
30	Cable clip	Support			
31	Insulation WT 18-22 kW	Isolation WT 18-22			

Übersetzungsliste
List of translations

Liste des traductions

Pos	Description	Description			
31	Insulation WT 30-35 kW	Isolation WT 30-35			
33	Adapter concentric for GB125, Ø80/125	Adaptateur concentric GB125 Ø80 /125			
34	Seal Flue gas 30-35 Al everp	Joint gas 30-35 Al			
34	Seal flue gas distribution 18-22KW AL ev	Joint 18-22kW			
36	spring clip d=32,6/22 everp clip d=32,6/	Pince à ressort d=32,6/22			
36	Spring d=38,2/28	Pince à ressort d=38,2/28			
37	Spring plug D26 everp plug D26 everp	Fiche à ressort D26			
38	isolation thread rod 36,2 rpack	Isolation barre fileté 36,2			
38	Sleeve 17,2x2,1x63,5 packed	Entretoise 17,2x2,1x63,5			
39	Conn union 2/3 R3/4" everp	Raccord sonde sanitaire 2/3 R3/4"			
39	Hose connector G3/4x20 angled	Embout G3/4x20 équerre			
40	Tube set DN20 DN20 (3m)	Tuyau DN20 (3m)			
41	Tee	Kit depart			
41	T-connect 60 kW sp	T-connect 60 kW sp			
42	Seal D18x30x2 EPDM packed	joint			
43	Seal D27x38x2 DVGW packed	Joint D27x38x2mm C4400 Klinger SIL			
45	Wire Data ext. Gassensor 330 everp	Câble			
48	Sealing-Set Siphon	Kit de joints pour siphon			
5	Element of construction	Groupe d'assemblage			
2	Wire Burner Oil BE 2.3-60 K RLA	brûleur fioul BE 2.3-60 K RLA			
2	Burner Oil BE 1.3-18 cpl V3 sp	brûleur fioul BE 1.3-18 kpl V3			
2	Burner Oil BE 1.3-22 cpl V3 sp	Brûleur fioul BE 1.3-22 V3			
2	Burner Oil BE 2.3-30 cpl V3 sp	brûleur fioul BE 2.3-30 kpl V3			
2	Burner Oil BE 2.3-35 cpl V3 sp	brûleur fioul BE 2.3-35 kpl V3			
2	Burner Oil BE 2.3-49 cpl V3 sp	brûleur fioul BE 2.3-49 kpl V3			
5	Service-Set BE 18kW everp	Set de service BE 18kW			
5	Service-Set BE 22kW everp	Set de service BE 22kW			
5	Service-Set BE 30kW everp	Set de service BE 30kW			
5	Service-Set BE 35kW everp	Set de service BE 35kW			
5	Service-Set BE 49kW everp	Set de service BE 49kW			
5	Service-Set BE 60kW everp	Set de service BE 60kW			
6	Element of construction	Groupe d'assemblage			

Übersetzungsliste
List of translations

Liste des traductions

Pos	Description	Description			
1	Motor HG 150W without Clutch	Moteur hg 150w avec accoupl			
1	Motor HG 170W without Clutch	Moteur hg 170 w			
2	capacitor 4MF, 400V AEG	Condensateur 4MF, 400V AEG			
2	Capacitor 5MF 450V f Hidria 150W	Condensateur 5MF 450V f Hidria 150W			
2	Capacitor 6MF 470V f Hidria 170W everp	Condensateur 6MF 470V f Hidria 170W			
2	capacitor 5MF	Condensateur 5MF			
3	Clutch white (2x)	Accoupl mot.- pompe fioul 2 meplats(2x)			
4	Cylinder head screw DIN912 M5x12 (10x)	VIS CYLINDRIQUE DIN912 M5x12 (10x)			
5	Stud Threaded M8x25/D13/ K105	BOULON FILETE M8x25/D13/ K105			
6	cabl e feed D 14/4mm	PASSE FIL D 14/4MM			
7	Pressure test nozzle R 1/8" MS	BUSE MESURE R 1/8			
8	cabl e feed D 29x11x4	Passe fill D 29x11x4			
9	Pin threaded DIN916 M6x8 (3x)	Tige filetée DIN916 M6x8 (3x)			
10	Cylinder-head screw DIN7984 M8x25 8.8 A3	VIS A TETE CYLINDRIQUE DIN7984 M8X25 8.8			
11	Distribution cylinder HG-A V1	Cylindre distributeur HG-A 17,34			
11	Distribution cylinder HG-A for 45,55kW	DEFLECTEUR D'AIR HGA 45-55 KW			
11	Distribution cylinder HG-A radial 4,9	REPART AIR CYLINDRE DISTR.			
12	O-ring 92x3	Joint etancheite d 93x3 mm4			
13	gasket D128x2	Joint D128x2			
14	Burner flange HG-A	BRIDE DE BRULEUR HG-A			
15	gasket 143x143x6 V3	Joint 143x143x6 V3			
16	impeller D133x38,4mm	Turbine extracteur D133x38,4mm			
16	impeller D133x59,8mm	Turbine extracteur D133x59,8mm			
17	Housing lid HG-A size 1	Couvercle HG-A Gr. 1			
17	Housing lid HG-A size 2	Couvercle HG-A Gr. 2			
18	Screw Pan-Head ISO7380 M5x20 (5x)	Vis à tête bombée ISO7380 M5x20 (5x)			
19	Inlet air duct HG-A size 1	DEFLECTEUR ASPIRATION HG-A MOD1 17-28KW			
19	Inlet air duct HG-A size 2	DEFLECTEUR ASPIRATION HG-A MOD2 34KW			
20	Inlet silencer HG-A RLU	Silencieux aspiration hg a RLU			
21	Silencer suction HG-A V3 cpl	Silencieux aspiration HG-A V3 cpl			
22	Screw Pan-Head ISO7380 M5x8 (5x)	Vis à tête bombée ISO7380 M5x8 (5x)			
23	Hose air WaBi Santo DN63 L1600 packed	tuyau flexible pour air WaBiSanto DN63 L			

Übersetzungsliste
List of translations

Liste des traductions

Pos	Description	Description			
24	Clamp hose 60/80 packed	Collier de serrage 60/80			
25	Switch DL 10KH-5 Z 290/70 cpl sp	contrôleur pression DL 10KH-5 Z 290/70			
26	hose pressure switch	JEU DE FLEXIBLE BLEU/ ROUGE			
27	Screw Pan- Head ISO7380 M5x16 (5x)	Vis à tête bombée ISO7380 M5x16 (5x)			
28	Switch DL 10KH-5 Z 100/70 cpl sp	contrôleur pression DL 10KH-5 Z 100/70			
28	Switch DL 10KH-5 Z 140/70 cpl sp	Contrôleur pression DL 10KH-5 Z 140/70			
29	hose pressure switch GB125 sp	JEU DE FLEXIBLE BLEU/ ROUGE GB125			
7	Element of construction	Groupe d'assemblage			
2	Housing Terminal cover SAFe	Couvercle safe GB402			
3	Control_box SAFe30 V7 DNA SP	SAFe30 V7 DNA			
4	Housing lower section SAFe	BOITIER ARRIERE SAFE			
5	Adapter H05V-K 0,75 0.8/2.0 gn/ge	Adapteur H05V-K 0,75 0,8/2,0 gn/ge			
6	Module BIM30 V10 GB125-60 everp	module BIM30 V10 GB125-60			
6	Module BIM30*-LoI/01 V10 18-49	Module BIM30*-LoI/01 V10 18-49			
8	Connection line SAFe motor BE	CABLE SAFE - MOTEUR			
8	Cable Motor 380 everp	câble de connexion Moteur 380			
9	Cable Ignition 410 everp	câble de connexion allumage 410			
9	Ignition cable SAFe 230 V	Cable allumage - safe			
10	Connection line Oil pre-heater SAFe BE	Cable rechauffeur - safe			
10	Cable Oil heater 375 everp	Cable rechauffeur 375			
12	UV-flaming sensor QRC SAFe BZ/BE_3	Detect flam qrc safe BZ/BE			
13	Support pipe extension BE_3 RLU V2	Tube de vise cellule BE_3 RLU V2			
14	Pipe holds HG V4 everp	TUBE MAINTIEN HG V4 BRULEUR BE			
15	igniter sensor cable BE/BE-A	Cable allumBE /BE-A			
15	Ignition Reaktanz 1550 Ohm 275mm everp	CABLE ALLUM Reakt. 1550 Ohm 275mm			
16	Ignition Danfoss EBI V4 spare part	Transformateur allumage ebi danfoss v4			
17	Data cable SAFe MC10 BE	Cable bus safe - MC10			
18	Con cable sensor SAFeBE grommet	Cable safe - sonde chaudiere			
18	Cable sensor SAFe 1900 everp	Capteur SAFe 1900			
19	Cable SAFe Power 1250 everp	câble de réseau SAFe 1250			
20	Cable MV 1 Pressure 320/580 everp	câble de connexion imprimer 320/580			
8B	Element of construction	Groupe d'assemblage			

Übersetzungsliste
List of translations

Liste des traductions

Pos	Description	Description			
1	Pump Oil Suntec ALEV35C everp	Pompe fioul suntec alev 35c			
1	Pump oil Suntec ALEV55C everp	Pompe fioul suntec alev 55c			
2	solenoid coil Suntec 220-240V/50-60Hz	Bobine electrovanne pompe suntec			
3	filter oil pump A70 Rev.3 AS 47 (2x)	Filtre Pompe à fioul A70 Rev.3 AS47 (2x)			
4	gasket oil pump ALE 35/55 (2x)	JOINT COUVERCLE POMPE SUNTEC AS 47 (2x)			
5	Hose set BE/RE	Conduit flexible set BE			
6	Screw connection XGE 4LLR 1/8" cyl.	RACC DROIT VIS XGE 4 LLR 1/8"			
7	Oil_pipe HG-A	TUBE ALIM FIOUL HG-A			
8	Coil solenoid BFP 21/31 L3	Bobine electrovan bfp 31 l3 pompe danfos			
9	filter oil pump BFP 21/31 L3 (2x)	Filtre pompe fioul danf bfp 21/31 l3 (2x)			
10	Clutch white (2x)	Accoupl mot. - pompe fioul 2 meplats(2x)			
11	Screw connection 3/8x1/4" straight	RACCORD 3/8"X1/4",DROIT			
12	Washer 13x18x1,5 (5x)	Joint 13x18x1,5 (5x)			
9A	Element of construction	Groupe d'assemblage			
1	disc D9,5/14x4 Ver02	RONDELLE D9,5/14X4 VER02			
2	Compres spring DIN2098 1,8x12,5x36	RESSORT DIN2098 1,8x12,5x36			
3	Preheater oil FPHE-LE 030N5129 PTC50	Prechauffeur fioul FPHE-LE 030N5129PTC50			
3	Preheater oil FPHB5-LE PTC70 B10	Brul rechauff fphb 5/30n			
4	Cut-off valve LE6 sp	Clapet retenu le6			
5	Nozzle oil 0.55gph 60gr HR Danfoss everp	gicleur fioul 0.55gph 60gr HR Danfoss			
5	oil nozzle 1,00gph 60° H Danfoss	Gicleur fioul 1,00gph 60° H Danfoss			
5	oil nozzle 0,45gph80Gr HFD Danfoss	Gicleur 0,45/80° HFD (danfoss)			
5	oil nozzle 0,85gph 60° H	Gicleur fioul 0,85gph 60° H			
5	Oil nozzle 0,35gph 80Gr HR	Gicleur 0,35/80° hr			
5	Oil nozzle 0,45gph80Gr HFD Danf.(12x)	Gicleur fioul 0,45gph80Gr HFD Danf.(12x)			
5	Oil nozzle 0,35gph80Gr HR Danf(10x)	Gicleur fioul 0,35gph80Gr HR Danf(10x)			
5	Nozzle for Oil 0.65gph 80°	Injecteur 0.65gph 80°			
5	Oil Nozzle 0,55gph 60Gr HR Danfoss10Pack	Oil Nozzle 0,55gph 60Gr HR Danfoss10Pack			
6	Mixer system BE 12,0/25,0/5,0/25	Chambre de melange BE 12,0/25,0/5,0/25			
6	Mixer system BE BE 12,1/27,5/5,8/25	SYSTEME DE MELANGE BE POUR GB125 22KW			
6	Mixer system BE 12,1/27,5/6,9/25 VA	SYSTEME DE MELANGE BE POUR GB125 30KW			
6	Mixer system BE 12,4/27,5/8,3/25 VA	SYSTEME DE MELANGE BE POUR GB125 34KW			

Übersetzungsliste
List of translations

Liste des traductions

Pos	Description	Description			
6	Mixer system BE/BE-A 2.1-43/45kW	SYSTEME MELANGEUR BE/BE-A 2.1-43/45			
6	Mixer system BE-55kW	SYSTEME MELANGEUR BE-55KW			
7	ignition electrode BE-BE-A Typ4 L34	Electrode d'allumage BE-BE-A Typ4 L34			
7	Ignition electrode BE Type 4 L50 V2	Électrode d'allumage BE Typ4 L50 V2			
7	Ignition electrode BE T4 L58,5 V2	électrode d'allumage BE T4 L58,5 V2			
8	Screw cheese-head DIN 912 M4x10 (5x)	VIS A TETE CYLINDRIQUE DIN912 M4X10 (5X)			
9	Sealing D75,5 V2	Joint tuyere BE 1.0/1.1/2.0/2.1			
9	Seal D81 V2 everp	JOINT DE TUYERE D81 V2			
10	Blast tube D69/L214 18kW	Tuyere 69/I214 sic 18kw			
10	Blast tube D83/L214 25kW	Tuyere GB125BE 25kw			
10	blast tube D83/L224/5,9/4,8 SiC	Tuyere GB125 BE 30kw			
10	blast tube D83/L224/7,0/5,7 SiC	Tuyere GB125 BE 125 35 kw			
10	Blast tube D83/L224/5,7/5,4 SiC	Tuyere d83/I224/5,7/5,4 sic			
11	Screw Pan-Head ISO7380 M5x8 (5x)	Vis à tête bombée ISO7380 M5x8 (5x)			
12	Support tube L50	TUBE DE SUPPORT L50			
13	O-ring 92x3	Joint etancheite d 93x3 mm4			
14	Burnertube D96/L257,5/5,5/4,9/4,9-8 eve	TUYERE GB225/55kW			
	Installation material oil burner BE	Matériel de montage Brûleur fioul BE			
9B	Element of construction	Groupe d'assemblage			
2	Screw M 3.5 x 12 (6x)	Vis M 3.5 x 12 (6x)			
3	Housing upper part blue	Carter partie superieure bleu			
4	Housing module carrier white	Module plaque de jonction blanc			
5	Fuse application 5x20 6,3AT 230V (10x)	Fusible arrière 5x20 6,3AT 230V (10x)			
6	Fuseholder cap	Support de fusible			
7	Connector 3-pole white	Borne de connexion 3- pôles blanc			
8	Connector 3-pol. SF50 pink	Borne de raccordement 3-poles SF50 rose			
9	Wire Power HV 1270 Ferrit everp	faisceau de câbles Power HV 1270 Ferrit			
11	Connector 4-pol 17B18 orange	Borne de raccordeme 4 poles 17B18 orange			
12	Connecting terminal pluggable 3-pol	Borne de connexion 3- pôles jaune			
13	Connector 4-pole SH I violet	Borne de connexion 4- pôles SH I violet			
14	Connector 3-pole PS grey	Borne de connexion 3- pôles ps gris			
15	Connector 3-pole PZ violett	Connecteur 3 poles violet			

Übersetzungsliste
List of translations

Liste des traductions

Pos	Description	Description			
16	Connector 3-pole PH green	Borne de connexion 3- pôles PH vert			
18	Connector 3-pol. AS red sparepart	Borne de raccordement 3-poles AS rouge			
19	Connecting terminal 2-polig WA maygreen	Fiche verte 2 poles wa			
20	Connector 2- pin blue	Borne de connexion 2- pol r5 bl everp			
21	Connector 2-pole grey FW	Borne de connexion 2- pôles gris FW			
22	Connect. term. 2-polig red	Fiche rouge 2 poles			
23	Connector 2- pin orange RC	Borne de connexion 2- pôles orange RC			
24	Connector 2-pole white	Borne de connexion 2-poles blanc			
30	Housing strain relief control (10x)	Décharge de traction (10x)			
31	Printed circuit board MC110 S14 blue	Circuit imprimé MC110 S14 bleu			
34	Strand set bus BC110-IMC110	Jeu de câbles Bus BC110-IMC110			
35	Control_panel BC110 S04	Module de commande BC110 S04			
36	Housing flap BC110	Couvercle BC110			
55	Cover RC3xx black	Revêtement RC3xx noir			
	Temperature sensor RD 6,0 10kΩ 3000mm	Sonde de température RD6,0 10kOHM 3000mm			
	Buderus Logamatic MC110 S14 blue	Buderus Logamatic MC110 S14 blau verp			
	LAN-Cable RJ45 Cat.5 2000	LAN-câble 2000			
	Outdoor temperature sensor	Sonde de température extérieure			
	Heat conducting paste 20 ML	Pate Thermocond. 20 ML.			

Gerätetypen
Types of appliances

Types de chaudières

Gerät Appliance Chaudière		Land Country Pays	Bemerkungen Remarks Remarques
GB125-60	8 732 911 612	AT,BE,CH,DE,LU	
GB125-18	7 736 601 552	AT,DE,PL	
GB125-22	7 736 601 553	AT,DE,PL	
GB125-30	7 736 601 554	AT,DE,PL	
GB125-35	7 736 601 555	AT,DE,PL	
GB125-49	7 736 601 556	AT,DE,PL	

Bosch Thermotechnik GmbH
Sophienstr. 30-32
D-35576 Wetzlar / Germany

Buderus