

# GB212 MC40, MC100

## 15-50kW

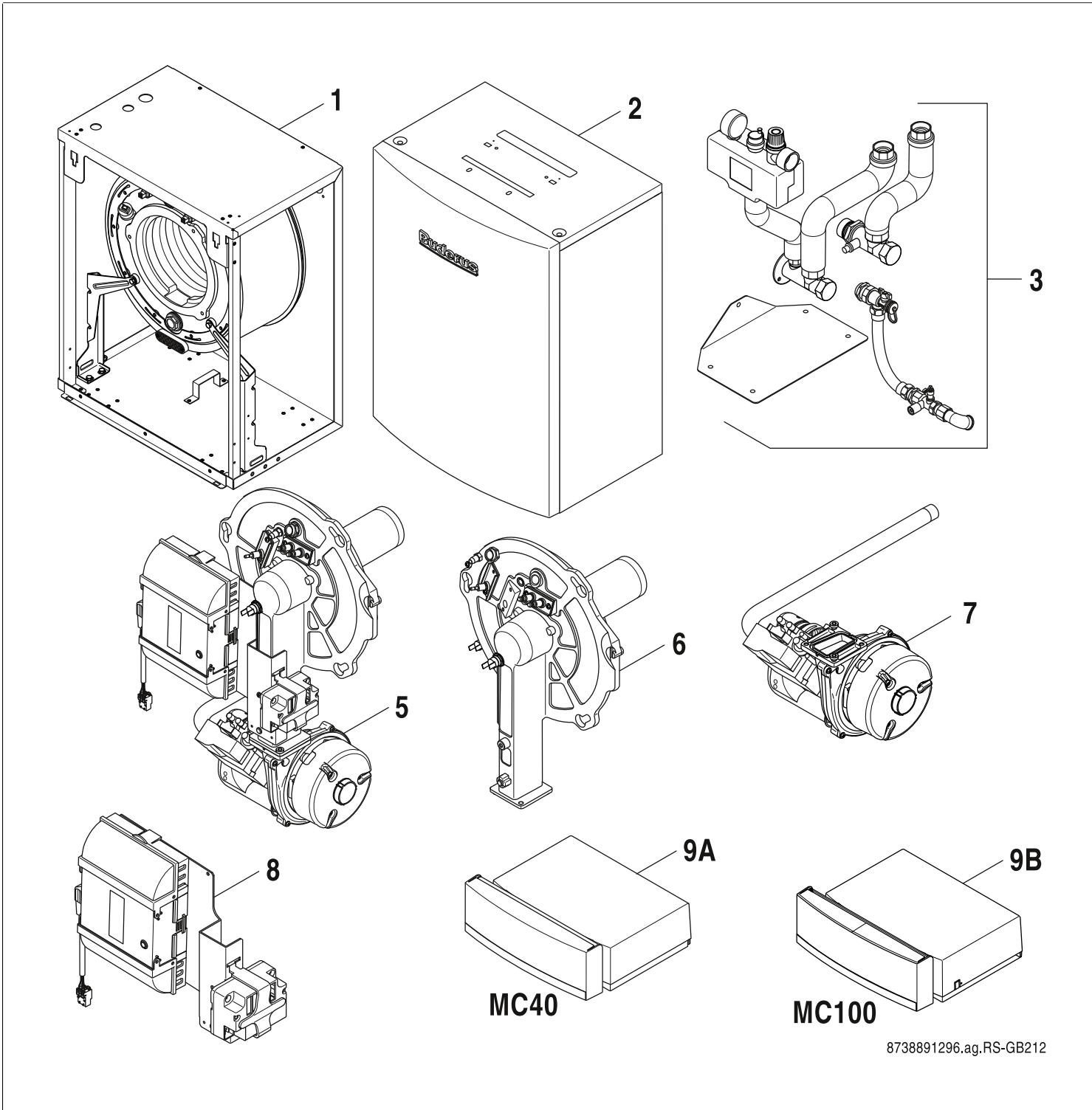

8738891296.ag.RS-GB212



**[de] Wichtige Hinweise zur Installation/Montage**

Die Installation/Montage muss durch eine für die Arbeiten zugelassene Fachkraft unter Beachtung der geltenden Vorschriften erfolgen.

**[en] Important notes on installation/assembly**

The installation/assembly must be carried out by a qualified contractor, following these instructions and in compliance with the applicable regulations.

**[fr] Instructions importantes pour l'installation/le montage**

L'installation/le montage doit être effectué(e) par un spécialiste qualifié pour les opérations concernées et dans le respect de la présente notice et des prescriptions applicables.

**[bg] Важни указания във връзка с инсталацията/монтажа**

Инсталацията/монтажът трябва да се извършва от лицензиран за работите специалист в съответствие с настоящото ръководство и с приложимите разпоредби.

**[cs] Důležité pokyny k instalaci/montáži**

Instalaci/montáž musí při dodržení pokynů uvedených v tomto návodu a platných předpisů provést odborný pracovník s příslušným oprávněním pro tyto práce.

**[da] Vigtige anvisninger til installationen/monteringen**

Installationen/monteringen skal foretages af en godkendt installatør under overholdelse af denne vejledning og de gældende forskrifter.

**[el] Σημαντικές υποδείξεις για την εγκατάσταση/συναρμολόγηση**

Η εγκατάσταση/τοποθέτηση πρέπει να ανατίθεται σε εκπαιδευμένο για τις συγκεκριμένες εργασίες τεχνικό προσωπικό με τήρηση αυτών των οδηγιών καθώς και των σχετικών προδιαγραφών.

**[es] Indicaciones importantes para instalación/montaje**

La instalación/el montaje debe realizarla personal especializado que esté autorizado para realizar estos trabajos y que tenga en cuenta estas instrucciones y la normativa vigente.

**[et] Olulised juhised paigaldamiseks/montaažiks**

Paigaldamist/montaaži tohib läbi viia vaid selleks volitusi omav spetsialist, arvestades kehtivaid nõudeid.

**[nl-BE] Belangrijke aanwijzingen betreffende de installatie/montage**

De installatie/montage moet worden uitgevoerd door een voor de werkzaamheden geautoriseerde installateur rekening houdend met deze handleiding en de geldende voorschriften.

**[fi] Tärkeitä asennus- ja kokoonpano-ohjeita**

Näihin töihin hyväksytyin ammattiasentajan pitää suorittaa asennus- ja kokoonpanotyöt voimassa olevien määräysten mukaisesti.

**[hu] Fontos tudnivalók az installálás/szereléshez**

A telepítést/szerelést egy, a munkálatokra felhatalmazott szakembernek kell végeznie, jelen utasítás és az érvényes előírások figyelembevételével.

**[it] Avvertenze importanti per l'installazione/il montaggio**

L'installazione/il montaggio deve aver luogo ad opera di una ditta specializzata ed autorizzata in osservanza di queste istruzioni e delle direttive vigenti.

**[ka] მნიშვნელოვანი მითითებები ინსტალაციისთვის/მონტაჟისთვის**

ინსტალაცია/მონტაჟი უნდა განხორციელდეს საშუალებისთვის დამკვეთი კვალიფიციური პერსონალის მიერ, მოქმედი განაწესის დაცვით.

**[lt] Svarbios instaliavimo ir (arba) montavimo nuorodos**

Instaliavimo / montavimo darbus, laikydamiės šios instrukcijos reikalavimų ir galiojančių taisyklių, privalo atlikti šioms darbams įgalioti specialistai.

**[lv] Svarīgi norādījumi par iekārtas uzstādīšanu / montāžu**

Uzstādīšanu/montāžu jāveic atbilstošajiem darbiem sertificētam speciālistam, ievērojot šo instrukciju un spēkā esošos noteikumus.

**[nl] Belangrijke aanwijzingen betreffende de installatie/montage**

De installatie/montage moet door een erkend installateur volgens de geldende voorschriften worden uitgevoerd.

**[no] Viktig informasjon om installasjon/montering**

Installasjonen/monteringen skal gjennomføres av autoriserte installatører, og installasjonsanvisningen samt gjeldende forskrifter skal følges.

**[pl] Ważne wskazówki dotyczące instalacji/montażu**

Instalację/montaż powinien wykonać specjalista uprawniony do tego typu prac z uwzględnieniem informacji podanych w niniejszej instrukcji oraz aktualnie obowiązujących przepisów.

**[pt] Indicações importantes relativas à instalação/montagem**

A instalação/montagem deve ser efectuada por um técnico autorizado para os trabalhos, respeitando este manual e as prescrições válidas.

**[ro] Indicații importante privind instalarea/montajul**

Instalarea/montajul trebuie realizate de către un specialist autorizat pentru lucrările respective, respectându-se prezentele instrucțiuni și prescripțiile valabile.

**[ru] Важные указания по подключению/монтажу**

Подключение/монтаж должны выполнять только специалисты, имеющие допуск к выполнению таких работ, при соблюдении требований этой инструкции и действующих норм и правил.

**[sk] Dôležité pokyny týkajúce sa inštalácie/montáže**

Inštaláciu/montáž musí vykonať odborný personál, ktorý má oprávnenie pre výkon týchto prác, pričom musí dodržiavať pokyny uvedené v tomto návode a platné predpisy.

**[sl] Pomembni napotki za namestitvev/montažo**

Inštalacijo/montažo lahko izvede samo pooblaščen strokovnjak ob upoštevanju teh navodil in veljavnih predpisov.

**[sr] Važna uputstva za ugradnju i montažu**

Ovu instalaciju/montažu moraju da obave stručna lica koja su ovlašćena za obavljanje takvih radova u skladu sa ovim uputstvom i važećim propisima.

**[sv] Viktiga anvisningar för installation/montering**

Installationen/monteringen måste utföras av en behörig och tekniskt utbildad person enligt denna anvisning samt gällande föreskrifter.

**[tr] Kurulum/Montaj ile ilgili önemli uyarılar**

Kurulum/montaj, bu çalışmalarını yapmasına müsaade edilen uzman kişiler tarafından işbu kılavuz ve geçerli yönetmelikler dikkate alınarak yapılmalıdır.

**[uk] Важливі вказівки щодо установки/монтажу**

Встановлення/монтаж повинні виконувати фахівці, що допущені до виконання таких робіт, із дотриманням цієї інструкції та діючих приписів.

**[zh] 安装方面的重要提示**

安装和组装工作必须由经过许可的专业人员进行, 同时必须遵守本说明书和现行法规的相关要求

**[ar] ملاحظات هامة للتركيب/التجميع**  
يجب أن يتم التركيب/التجميع من قبل متخصص مصرح له بالعمل، مع مراعاة اللوائح السارية.

**[fa] تذکرات مهم درباره نصب/مونتاژ**  
نصب/مونتاژ باید توسط فردی حرفه ای که مجاز به انجام این کار است، و همچنین با توجه کامل به مقررات مربوطه انجام شود.

**[az] Quraşdırılma**

Quraşdırılma işinin yerinə yetirilməsi səlahiyyətli bir mütəxəssis tərəfindən və müvafiq qaydalara uyğun olaraq aparılmalıdır.

**Ersatzteilliste**  
**Spare parts list**

**Liste des pièces de rechange**  
**Lista parti di ricambio**

**Onderdelenlijst**  
**Lista de repuestos**

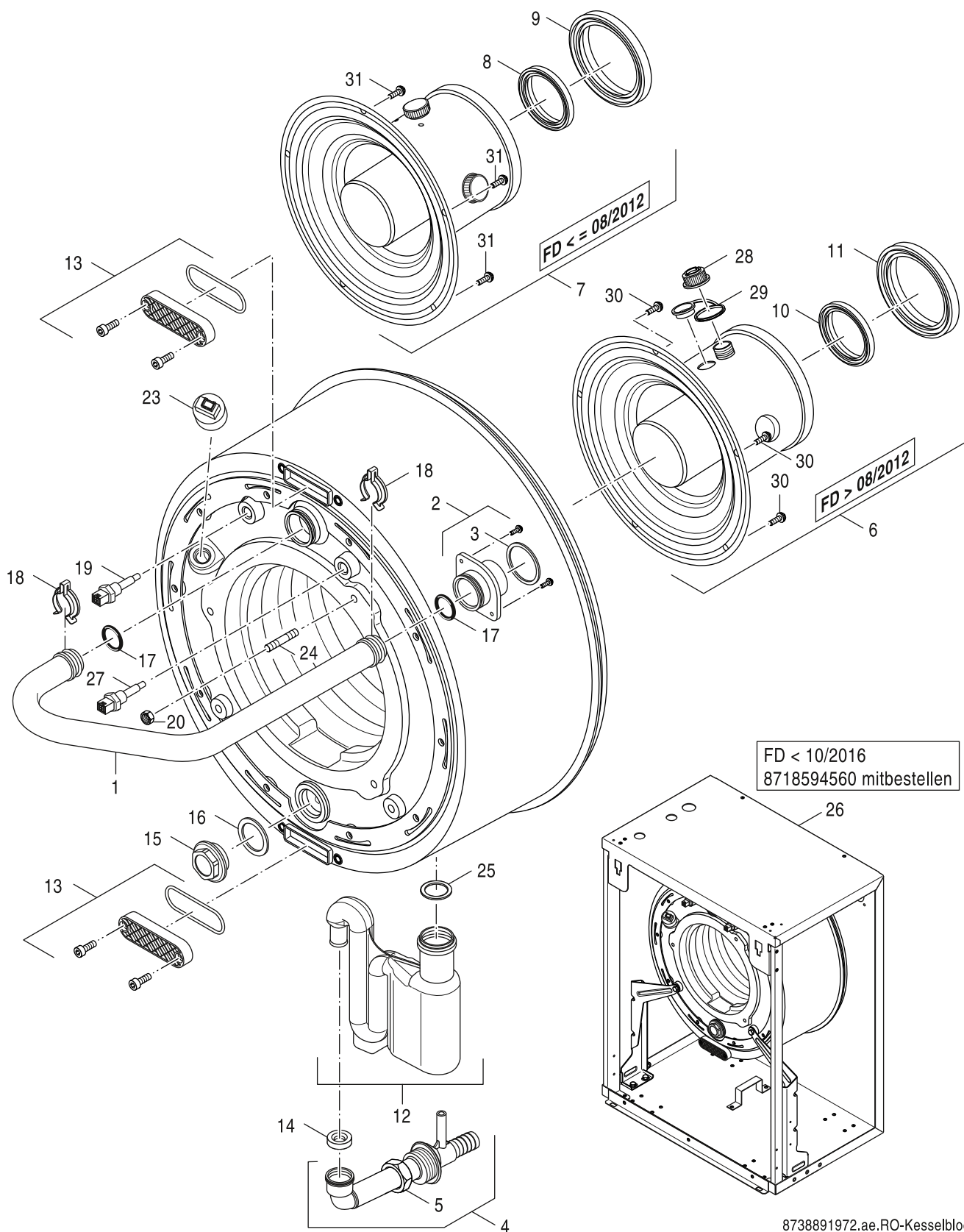

8738891972.ae.RO-Kesselblock

1  
Kesselblock  
Boiler block  
Bloc chaudière  
Corpo caldaia  
Ketelblok  
Cuerpo de caldera

**GB212 MC40, MC100**  
**15-50kW**





Pos	Bezeichnung Description Dénomination Descrizioni Benaming Descripción		GB212-15/5	GB212-15/5 IP	GB212-22/6	GB212-22/6 IP	GB212-30	GB212-30/6	GB212-30/9	GB212-40/10	GB212-50/10									Bemerkungen Remarks Remarques Osservazioni Opmerkingen Observaciones
1	Vorderwand blau	8 718 583 085	■	■	■	■	■	■	■	■	■									
2	Geräteschild "Buderus" everp	8 718 583 088	■	■	■	■	■	■	■	■	■									
4	Haube außen blau 5-6 Gld everp	8 718 583 091	■	■	■	■	■	■												FD>08/2014
4	Haube außen blau 9-10 Gld everp	8 718 583 092					■	■	■	■										FD<=08/2014
6	Isolierung vorne everp	8 718 586 489	■	■	■	■	■	■	■	■	■									
7	Seitenwand re/li blau 5-6 Gld everp	8 718 586 488	■	■	■	■	■	■												FD>08/2014
7	Seitenwand re/li blau 9/10 Gld everp	8 718 587 794					■	■	■	■										FD<=08/2014
8	Wärmeschutz Block 5Gld everp	8 718 583 209	■	■																
8	Wärmeschutz Block 6Gld everp	8 718 583 210			■	■	■	■												FD>08/2014
8	Wärmeschutz Block 9Gld everp	8 718 583 212					■	■												FD<=08/2014
8	Wärmeschutz Block 10Gld everp	8 718 583 213								■	■									
9	Flachkopfschraube ST3,9x9,5 A3T (10x)	7 747 026 999	■	■	■	■	■	■	■	■	■									
10	Montageset Vorderwand everp	8 718 583 089	■	■	■	■	■	■	■	■	■									
11	Haltefeder (10x) everp	7 747 016 084	■	■	■	■	■	■	■	■	■									
12	Gerätefuß M10x51 everp (4x)	6 302 865 7	■	■	■	■	■	■	■	■	■									
13	Kabeldurchführung D46 / 4019 everp	8 718 583 389	■	■	■	■	■	■	■	■	■									
	Wärmeschutz vorne everp	8 718 583 093	■	■	■	■	■	■	■	■	■									FD<07/12
	Wärmeschutz 30-40kW li/re everp	8 718 583 094					■	■	■	■	■									FD<07/12
	Wärmeschutz 15-22kW oben everp	8 718 583 095	■	■	■	■														FD<05/12
	Wärmeschutz 30-40kW oben everp	8 718 583 096					■	■	■	■	■									FD<07/12
	Wärmeschutz 15-22kW li/re everp	8 718 583 098	■	■	■	■														FD<05/12

**GB212 MC40, MC100  
15-50kW**

Verkleidung  
Casing  
Habillage  
rRvestimento  
Mantel  
Revestimiento

**2**





Pos	Bezeichnung Description Dénomination Descrizioni Benaming Descripción		GB212-15/5	GB212-15/5 IP	GB212-22/6	GB212-22/6 IP	GB212-30	GB212-30/6	GB212-30/9	GB212-40/10	GB212-50/10									Bemerkungen Remarks Remarques Osservazioni Opmerkingen Observaciones
1	T-Stück G1" mit Muffe G3/4" VL everp	8 718 583 167	■	■	■	■	■	■	■	■										FD<=11/2013
1	T-Stück G11/2 mit Muffe G3/4 VL everp	8 718 595 433									■									
1	T-Stück G1 mit Muffe G3/4 VL V3 everp	8 738 803 862	■	■	■	■	■	■	■	■										FD<=09/2016, 8718594560 mitbestellen
2	Dichtung D27x38x2 DVGW-zugelassen everp	8 718 584 801	■	■	■	■	■	■	■	■										
2	Dichtung D32x44x2, DVGW-zugelassen everp	8 718 585 153									■									alternativ
2	Dichtungs-Set D32x44x2 AFM34 (5x) everp	8 718 660 766 0									■									alternativ
4	Dichtung D17x24x2, DVGW-zugelassen	5 662 330	■	■	■	■	■	■	■	■	■									
5	T-Stück G1" mit Muffe G1/4" RL everp	8 718 583 166	■	■	■	■	■	■	■	■										FD<=11/2014
5	T-Stück G1 mit O-Ring RL everp	8 718 594 563	■	■	■	■	■	■	■	■										FD>11/2014
5	T-Stück G11/2 mit Muffe G1/4 RL everp	8 718 595 434									■									
6	Dichtung D32x44x2 EPDM (5x) everp	6 301 012 3									■									
6	Dichtung D21x30x2mm (5x) everp	6 302 800 8	■	■	■	■	■	■	■	■										FD<=11/2014
6	O-Ring 29,82x2,62 EPDM (x5) everp	8 718 594 562	■	■	■	■	■	■	■	■										FD>11/2014
6	O-Ring 37x3 EPDM (5x) everp	8 718 595 435									■									
7	Kappe G11/2x16 everp	6 301 507 5					■	■			■									
7	Verschlusskappe G1" everp	8 718 585 244	■	■	■	■	■	■	■	■										
8	Doppelnippel G1x31 mit O-Ring everp	8 718 583 176	■	■	■	■	■	■	■	■	■									
9	Füll und Entleerungshahn G1xG3/4 everp	8 718 585 245	■	■	■	■	■	■	■	■	■									
10	Metallwellschlauch DN16 1000mm everp	8 738 804 516	■	■	■	■	■	■	■	■	■									
11	Kappenventil flachdichtend 3/4x3/4 everp	6 302 542 7	■	■	■	■	■	■	■	■	■									
12	Halteblech Ausdehnungsgefäß	8 718 582 663	■	■	■	■	■	■	■	■	■									Zubehör
13	O-Ring 22x2,5mm 70EPDM/281 (5x) everp	8 718 585 539	■	■	■	■	■	■	■	■	■									
14	Dichtung D19x24,3x2mm AFM34 (5x) everp	8 718 571 898 0	■	■	■	■	■	■	■	■	■									
15	Verschraubung G1-G1 everp	8 718 583 177	■	■	■	■	■	■	■	■	■									für Wärmemengenzähler
16	Dichtung D24x30,5x2 AFM34 (1x) everp	8 718 585 269	■	■	■	■	■	■	■	■	■									
17	Doppelnippel G1x33 flachdichtend everp	6 303 627 0	■	■	■	■	■	■	■	■	■									für Wärmemengenzähler
18	KSS Verteilerbalken everp	8 718 583 178	■	■	■	■	■	■	■	■	■									
19	Anschlussrohr KSS 75x223 everp	8 718 583 179	■	■	■	■	■	■	■	■	■									FD<=09/2016
19	Anschlussrohr BSS2 / BSS5 G3/4 everp	8 718 594 560	■	■	■	■	■	■	■	■	■									FD>09/2016
20	Dichtung D17x24x2, DVGW-zugelassen	5 662 330	■	■	■	■	■	■	■	■										
20	Dichtung D17x24x2 AFM34 (10x)	7 747 016 505									■									
21	Wärmeschutz KSS Verteilerbalken everp	8 718 583 180	■	■	■	■	■	■	■	■	■									
22	Entlüfter Autom m. Absperrvent 3/8 everp	8 718 585 257	■	■	■	■	■	■	■	■	■									
23	Anschlussrohr RK G1 1/4" 139x217 everp	8 718 583 181	■	■	■	■	■	■	■	■	■									
23	Anschlussrohr RK G11/2 kpl everp	8 718 594 559									■									
24	Anschlussrohr VK G1 1/4" 217x219 everp	8 718 583 182	■	■	■	■	■	■	■	■	■									
24	Anschlussrohr VK G11/2 kpl everp	8 718 594 558									■									
26	Verschlusskappe G3/4 mit Dichtung everp	6 302 303 1	■	■	■	■	■	■	■	■	■									
27	Vor-/Rücklauffühler G1/4 45lg everp	6 304 167 7	■	■	■	■	■	■	■	■	■									
	Logafix MembranSicherheitsV 1/2" 3,0bar	8 080 503 0	■	■	■	■	■	■	■	■	■									
	Manometer 2,5bar 63mm AE D3/8"U	8 119 203 0	■	■	■	■	■	■	■	■	■									

**GB212 MC40, MC100  
15-50kW**

Anschlußteile  
Connection-parts  
Raccordement  
Collegamento  
Aansluiting  
Conexión

**3**

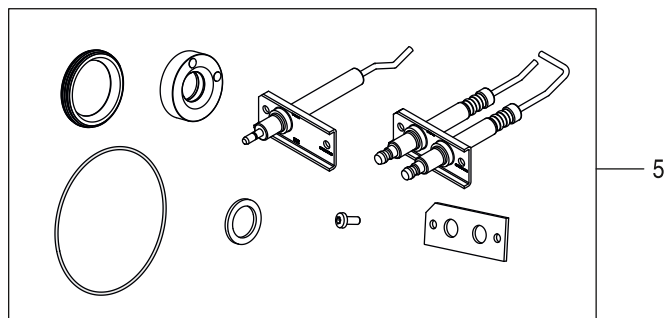
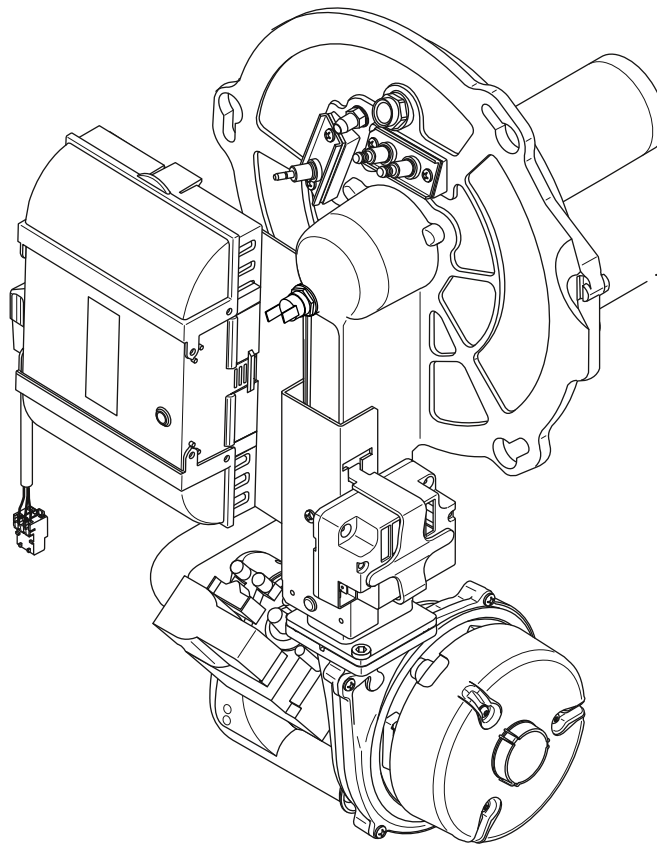

8738891240.ac.RS-Brennervarianten

**5** Brennervarianten  
burner versions  
Variantes de brûleur  
varianti del bruciatore  
brandervarianten  
Variantes de quemadores

**GB212 MC40, MC100  
15-50kW**

Pos	Bezeichnung Description Dénomination Descrizioni Benaming Descripción		GB212-15/5	GB212-15/5 IP	GB212-22/6	GB212-22/6 IP	GB212-30	GB212-30/6	GB212-30/9	GB212-40/10	GB212-50/10								Bemerkungen Remarks Remarques Osservazioni Opmerkingen Observaciones
1	Gasbrenner VM1.0 15kW G20 V2 everp	8 718 588 809	■	■															
1	Gasbrenner VM1.0 22kW G20 V2 everp	8 718 588 810			■	■													
1	Gasbrenner VM1.0 30kW G20 V2 everp	8 718 588 811					■		■										30kW/9 FD<08/2014
1	Gasbrenner VM1.0 40kW G20 V2 everp	8 718 588 812								■									
1	Gasbrenner VM1.0 15kW G25 V2 everp	8 718 588 813	■	■															
1	Gasbrenner VM1.0 22kW G25 V2 everp	8 718 588 814			■	■													
1	Gasbrenner VM1.0 30kW G25 V2 everp	8 718 588 815							■										30kW/9 FD<08/2014
1	Gasbrenner VM1.0 40kW G25 V2 everp	8 718 588 816								■									
1	Gasbrenner VM1.0 30kW/6Gld G20 everp	8 718 595 337					■	■											30kW/6 FD>08/2014
1	Gasbrenner VM1.0 50kW/10Gld G20 everp	8 718 595 338									■								
1	Gasbrenner VM1.0 30kW/6Gld G25 everp	8 718 595 339						■											
1	Gasbrenner VM1.0 50kW/10Gld G25 everp	8 718 595 340									■								
5	Service-Set VM1.0 everp	7 736 604 314	■	■	■	■	■	■	■	■	■								
	Umstt G20/G25	8 718 586 432	■	■	■	■	■	■	■										Zubehör
	Umstt VM1.0 50/10 G31 Flüssiggas V2	8 718 594 361									■								Zubehör
	Umstt VM1.0 30/6 G31 Flüssiggas V2	8 718 594 417					■	■											30kW/6 FD>08/2014/Zubehör
	Umstt Flüssiggas VM1.0 15 kW V2	8 718 596 736	■	■															Zubehör
	Umstt Flüssiggas VM1.0 22kW V2	8 718 596 737			■	■													Zubehör
	Umstt Flüssiggas VM1.0 30kW V2	8 718 596 738					■	■											Zubehör FD <08/2014
	Umstt Flüssiggas VM1.0 40kW V2	8 718 596 739									■								Zubehör

**GB212 MC40, MC100  
15-50kW**

Brennervarianten  
burner versions  
Variantes de brûleur  
varianti del bruciatore  
brandervarianten  
Variantes de quemadores

**5**

Ersatzteilliste  
Spare parts list

Liste des pièces de rechange  
Lista parti di ricambio

Onderdelenlijst  
Lista de repuestos

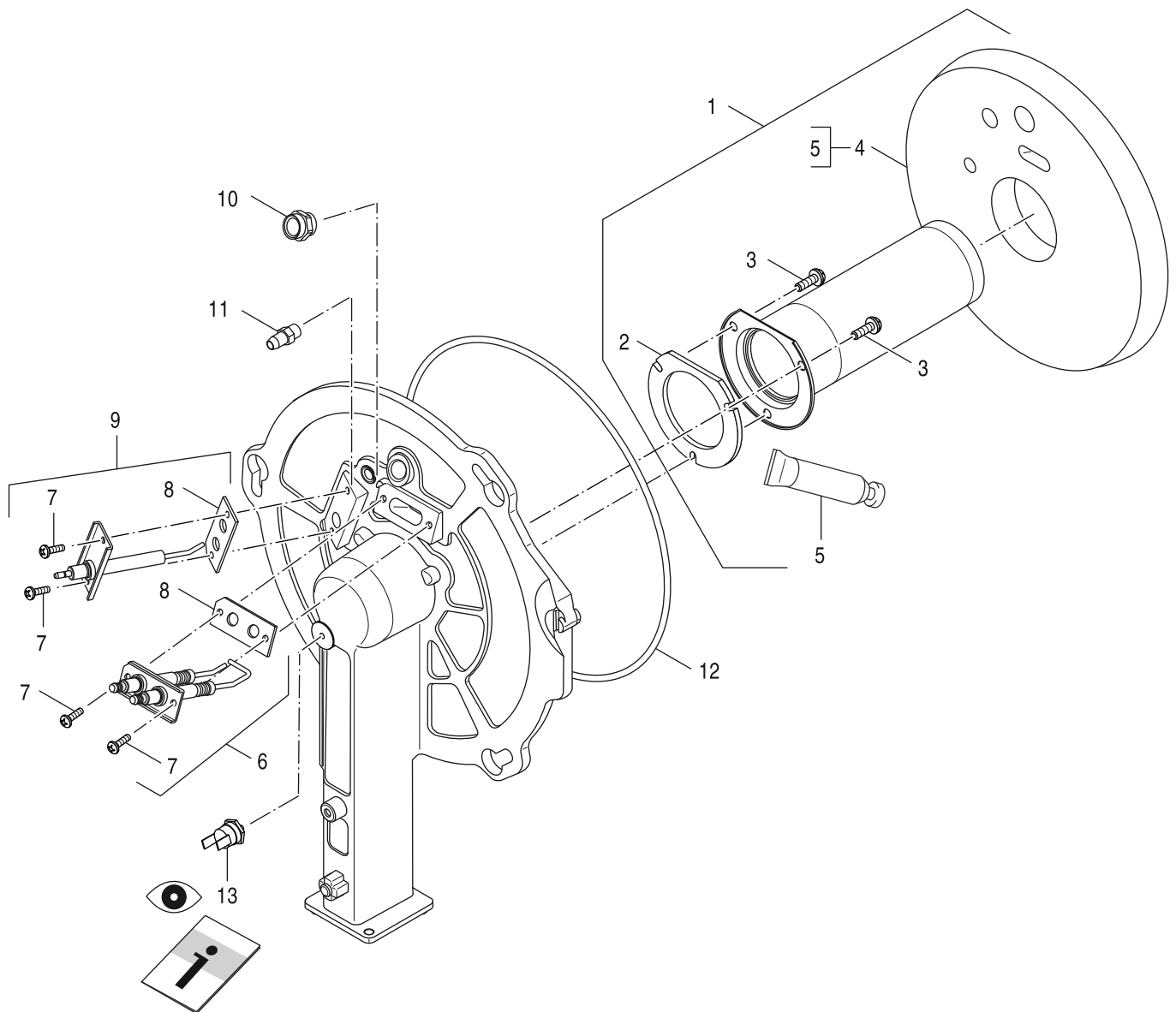

8738891241.ac.RS-Brennstab/Elektroden

**6**

Brennstab/Elektrode  
burner rod/electrode  
rampe de combustion/électrode  
torcia del bruciatore/Elettrodo  
Staafterander/elektrode  
barra combustible/electrodo

**GB212 MC40, MC100  
15-50kW**

Pos	Bezeichnung Description Dénomination Descrizioni Benaming Descripción		GB212-15/5	GB212-15/5 IP	GB212-22/6	GB212-22/6 IP	GB212-30	GB212-30/6	GB212-30/9	GB212-40/10	GB212-50/10									Bemerkungen Remarks Remarques Osservazioni Opmerkingen Observaciones
1	Brennstab Gasbr VM1.0 15/VM1.1 22kW ever	8 718 587 522	■	■																
1	Brennstab Gasbr VM1.0 22/VM1.1 30kW ever	8 718 587 523			■	■	■	■												30kW/6 FD>08/2014
1	Brennstab Gasbrenner VM1.0 30kW everp	8 718 587 524					■	■												30kW/9 FD<08/2014
1	Brennstab Gasbrenner VM1.0 40/50kW everp	8 718 587 525								■	■									
2	Dichtung Brennstab everp	8 718 586 629	■	■	■	■	■	■	■	■	■									
3	Schraube Ejot Altracs M6x14 (10x) everp	8 718 582 996	■	■	■	■	■	■	■	■	■									
4	Isolierung Brennerfl. VM1.0 15-40 everp	8 718 582 997	■	■	■	■	■	■	■	■	■									
5	Keramikleber 115gr Tube everp	8 718 576 016 0	■	■	■	■	■	■	■	■	■									
6	Zünderlektrode VM1.0 15-50kW everp	8 718 595 817	■	■	■	■	■	■	■	■	■									
7	Linsenschr DIN7985 M4x10 8.8A3K (4x) eve	8 718 583 000	■	■	■	■	■	■	■	■	■									
8	Dichtung Elektrode (2x) everp	8 718 583 001	■	■	■	■	■	■	■	■	■									
9	Überwachungselektrode VM1.0 15-50 everp	8 738 803 648	■	■	■	■	■	■	■	■	■									
10	Schauglas M16x1 kpl everp	8 718 589 884	■	■	■	■	■	■	■	■	■									
11	Druckmessdüse G1/8" Set	7 747 022 048	■	■	■	■	■	■	■	■	■									
12	O-Ring 253,37 x 5,33 everp	8 718 583 004	■	■	■	■	■	■	■	■	■									
13	Bimetallschalter 130°C everp	7 736 606 113	■	■	■	■	■	■	■	■	■									

**GB212 MC40, MC100  
15-50kW**

Brennstab/Elektrode  
burner rod/electrode  
rampe de combustion/électrode  
torcia del bruciatore/Elettrodo  
Staafrander/elektrode  
barra combustible/electrodo

**6**

**Ersatzteilliste**  
Spare parts list

**Liste des pièces de rechange**  
Lista parti di ricambio

**Onderdelenlijst**  
Lista de repuestos

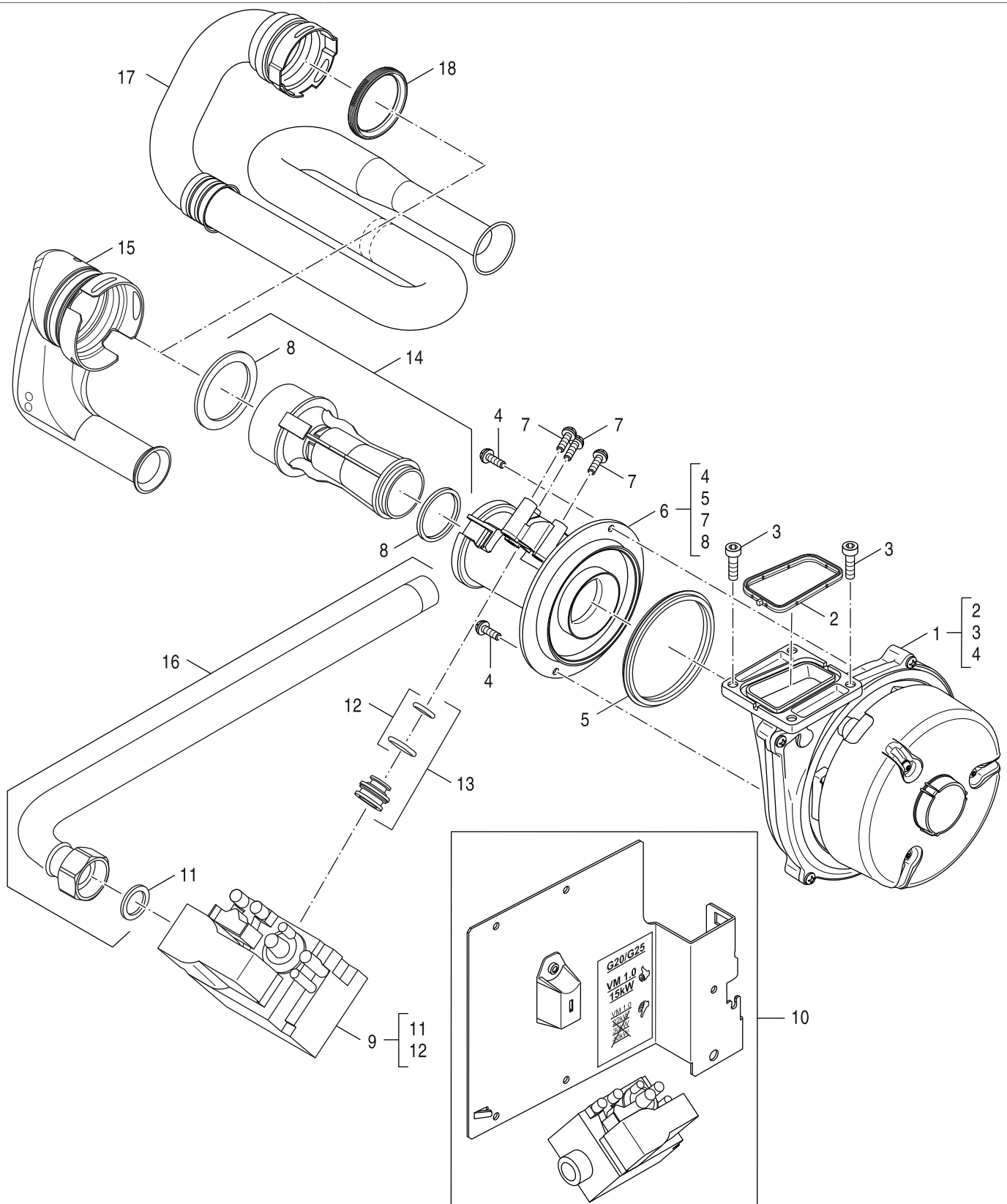

8738891242.ab.RS-Gasarmatur/Gebläse

**7**  
Gasarmatur/Gebläse  
gas valve/fan  
bloc gaz/Ventilateur  
Gruppo gas/Ventilatore  
Gasblok/ventilator  
válvula del gas/ventilador

**GB212 MC40, MC100**  
**15-50kW**

Pos	Bezeichnung Description Dénomination Descrizioni Benaming Descripción		GB212-15/5	GB212-15/5 IP	GB212-22/6	GB212-22/6 IP	GB212-30	GB212-30/6	GB212-30/9	GB212-40/10	GB212-50/10									Bemerkungen Remarks Remarques Osservazioni Opmerkingen Observaciones
1	GebläsePEBM D118 AC230 50 070W PWM MCeVe	8 718 593 107	■	■	■	■	■	■	■	■	■									
1	GebläsePEBM D118 AC230 50 120W PWM everp	8 718 595 370									■									
2	Dichtung (Gebläse)	8 718 660 208 0	■	■	■	■	■	■	■	■	■									
3	Schraube Ejot Altracs M6x14 (10x) everp	8 718 582 996	■	■	■	■	■	■	■	■	■									
4	Schraube 40x8/7 TORX (10x) everp	7 746 900 442	■	■	■	■	■	■	■	■	■									
5	Dichtung Venturi-Gehäuse	7 746 900 441	■	■	■	■	■	■	■	■	■									
6	Venturi-Gehäuse	7 746 900 440	■	■	■	■	■	■	■	■	■									
7	Schraube gasventil (10x)	7 746 900 443	■	■	■	■	■	■	■	■	■									
8	Flachdichtungs-Set für Luftdüse (2x5x)	7 099 021	■	■	■	■	■	■	■	■	■									
9	Gasventil SIT848 3/4" flw adjuster everp	8 718 586 434	■	■	■	■	■	■	■	■	■									15kW FD<31.12.12 - 8718588808 best.
10	Umbausatz Gasventil SIT848 15kW G20/G25	8 718 588 808	■	■																FD<31.12.2012
11	Dichtung D17x24x2 AFM34 (10x)	7 747 016 505	■	■	■	■	■	■	■	■	■									
12	O-Ring Set Gasdüse	7 099 018	■	■	■	■	■	■	■	■	■									
13	Gasdüse 5,05 mm	7 746 900 345			■	■														EG G20/G25
13	Gasdüse 5,90 [mm]	7 746 900 346					■	■	■											EG G20/G25
13	Düse D3,8 everp	8 718 583 007	■	■																EG G20/G25
13	Düse D7,8 everp	8 718 583 008								■										EG G20/G25
13	Düse D2,6 everp	8 718 583 541	■	■																FG G31
13	Düse D3,35 everp	8 718 583 542			■	■														FG G31
13	Düse D3,95 everp	8 718 583 543					■	■	■											FG G31
13	Düse D4,65 everp	8 718 583 544								■										FG G31
13	Düse D8,1 everp	8 718 595 368									■									EG G20/G25
13	Düse D4,8 everp	8 718 595 369									■									FG G31
14	Venturi 423.088A	7 099 019	■	■																
14	Venturi 423.072A	7 099 020					■	■	■											
14	Venturi 423.170A	7 099 925									■	■								
14	Venturi everp	8 718 583 009			■	■														
15	Gebläseansaugrohr	7 746 900 439			■	■														
16	Gasanschlussrohr VM1.0 15kW everp	8 718 583 010	■	■																FD<08.02.12
16	Gasanschlussrohr VM1.0 22kW everp	8 718 583 011			■	■														FD<08.02.12
16	Gasanschlussrohr VM1.0 30kW everp	8 718 583 012					■		■											FD<08.02.12
16	Gasanschlussrohr VM1.0 40kW everp	8 718 583 013								■										FD<19.02.12
16	Gasanschlussrohr VM1.0 15kW everp	8 718 585 651	■	■																FD>07.02.12
16	Gasanschlussrohr VM1.0 22/30kW everp	8 718 585 652			■	■	■	■												30kW/6 FD>08/2014/FD>07.02.12
16	Gasanschlussrohr VM1.0 30/9 everp	8 718 585 653					■		■											FD>07.02.12
16	Gasanschlussrohr VM1.0 40/50kW everp	8 718 585 654								■	■									FD>18.02.12
17	Gebläseansaugrohr	7 457 6								■										
18	Dichtung 50mm (5x)	7 099 058								■	■									

**GB212 MC40, MC100  
15-50kW**

Gasarmatur/Gebläse  
gas valve/fan  
bloc gaz/Ventilateur  
Gruppo gas/Ventilatore  
Gasblok/ventilator  
válvula del gas/ventilador

**7**

Ersatzteilliste  
Spare parts list

Liste des pièces de rechange  
Lista parti di ricambio

Onderdelenlijst  
Lista de repuestos

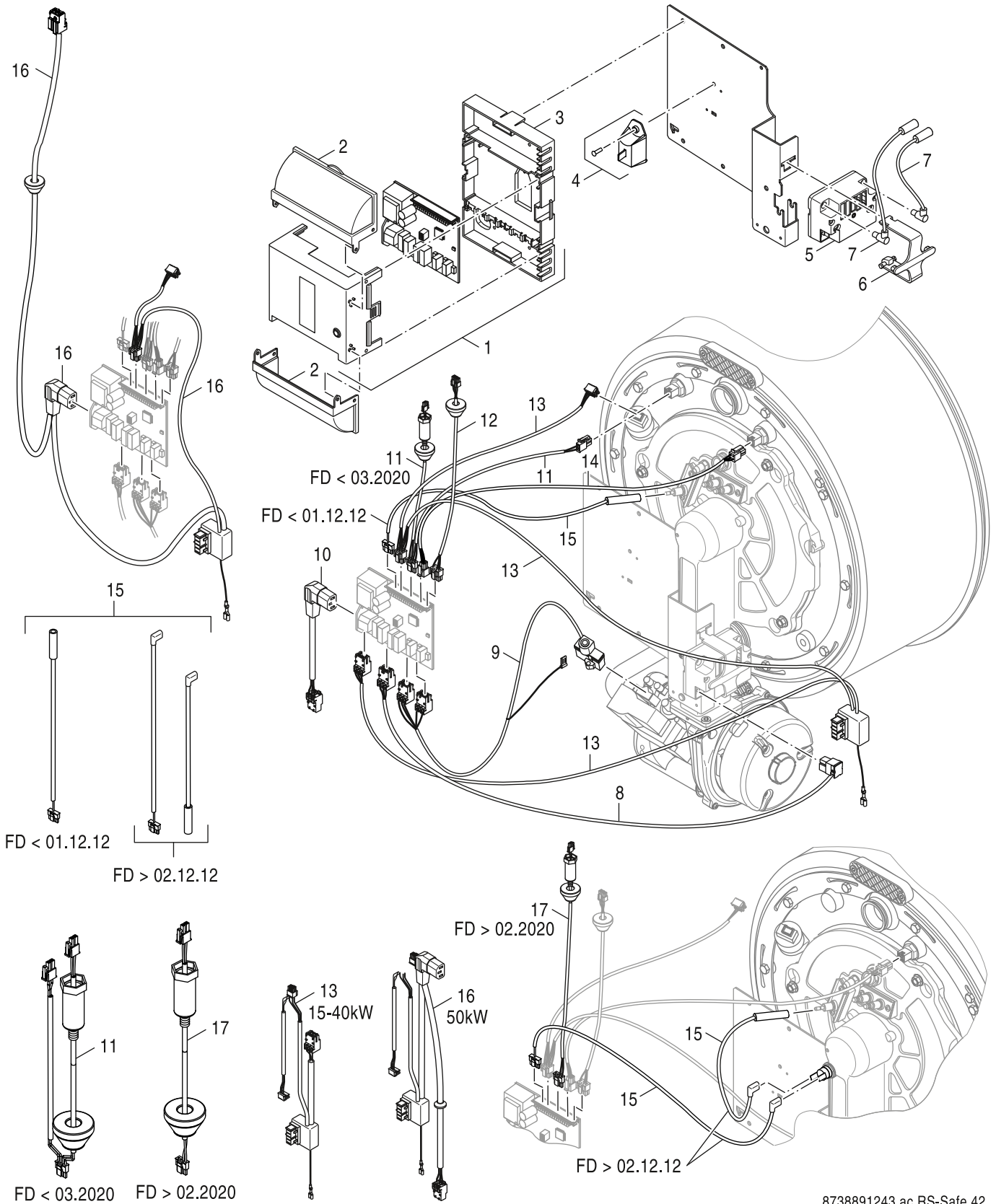

8738891243.ac.RS-Safe 42

**8**  
Safe 42  
Safe 42  
Safe 42  
Safe 42  
Safe 42  
Safe 42

**GB212 MC40, MC100  
15-50kW**



Pos	Bezeichnung Description Dénomination Descrizioni Benaming Descripción		GB212-15/5	GB212-15/5 IP	GB212-22/6	GB212-22/6 IP	GB212-30	GB212-30/6	GB212-30/9	GB212-40/10	GB212-50/10								Bemerkungen Remarks Remarques Osservazioni Opmerkingen Observaciones
1	SAFe42*1 V4/S07 everp	8 738 803 950	■	■	■	■	■	■	■	■	■								
2	Gehäuse Klemmenabdeckung SAFe everp	6 302 392 5	■	■	■	■	■	■	■	■	■								
3	Gehäuse Unterteil SAFe everp	6 302 393 0	■	■	■	■	■	■	■	■	■								
4	Modul BIM42 6201-V23 GB212 - 15 everp	7 736 604 133	■	■															Nur für Service-Techniker
4	Modul BIM42 6202-V23 GB212 - 22 everp	7 736 604 134			■	■													Nur für Service-Techniker
4	Modul BIM42 6303-V23 GB212 - 30 everp	7 736 604 135					■	■											FD>08/2014 Nur für Servicetechniker
4	Modul BIM42 6204-V23 GB212 - 40 everp	7 736 604 136								■									Nur für Service-Techniker
4	Modul BIM42 6305-V23 GB212 - 50 everp	7 736 604 137									■								Nur für Service-Techniker
4	Modul BIM42 6211-V23 GB212-15 FG everp	7 736 604 138	■	■															Nur für Service-Techniker
4	Modul BIM42 6212-V23 GB212-22 FG everp	7 736 604 139			■	■													Nur für Service-Techniker
4	Modul BIM42 6313-V23 GB212-30 FG everp	7 736 604 140					■	■											FD>08/2014 Nur für Servicetechniker
4	Modul BIM42 6214-V23 GB212-40 FG everp	7 736 604 141								■									Nur für Service-Techniker
4	Modul BIM42 6315-V23 GB212-50 FG everp	7 736 604 142									■								Nur für Service-Techniker
4	Modul BIM42 V22 - 30 everp	8 718 596 434					■	■											FD<=08/2014 Nur für Servicetechniker
4	Modul BIM42 V22-30-FG everp	8 718 596 440					■	■											FD<=08/2014 Nur für Servicetechniker
5	Zünderichtung Danfoss EBI V4 everp	8 718 575 099 0	■	■	■	■	■	■	■	■	■								
6	Halteclip Trafo EBI everp	8 718 583 015	■	■	■	■	■	■	■	■	■								
7	Zündleitung KD5 SD6,3 SD4 everp	8 718 583 016	■	■	■	■	■	■	■	■	■								
8	Verbindungsleitung SAFe - Zündung everp	8 718 581 880	■	■	■	■	■	■	■	■	■								
9	Verbindungsleitung SAFe - MV1 everp	8 718 581 878	■	■	■	■	■	■	■	■	■								
10	Verbindungsleitung SAFe - Netz everp	8 718 581 115	■	■	■	■	■	■	■	■	■								
11	Verbindungsleitung Fühler Vor/Rücklauf	8 718 581 879	■	■	■	■	■	■	■	■	■								
12	Datenleitung SAFe RMx 990mm everp	8 718 581 113	■	■	■	■	■	■	■	■	■								
13	Y- Kabel Fan Adapter everp	8 718 581 096	■	■	■	■	■	■	■	■	■								
14	Verbindungsleitung SAFe - FK everp	8 718 581 572	■	■	■	■	■	■	■	■	■								
15	Verb.leitung Ionisation K 125/230 everp	8 718 588 787	■	■	■	■	■	■	■	■	■								
16	Y Kabel Gebläseadapter GB212 50KW everp	8 718 595 271									■								

**GB212 MC40, MC100  
15-50kW**

Safe 42  
Safe 42  
Safe 42  
Safe 42  
Safe 42

**8**

Ersatzteilliste  
Spare parts list

Liste des pièces de rechange  
Lista parti di ricambio

Onderdelenlijst  
Lista de repuestos

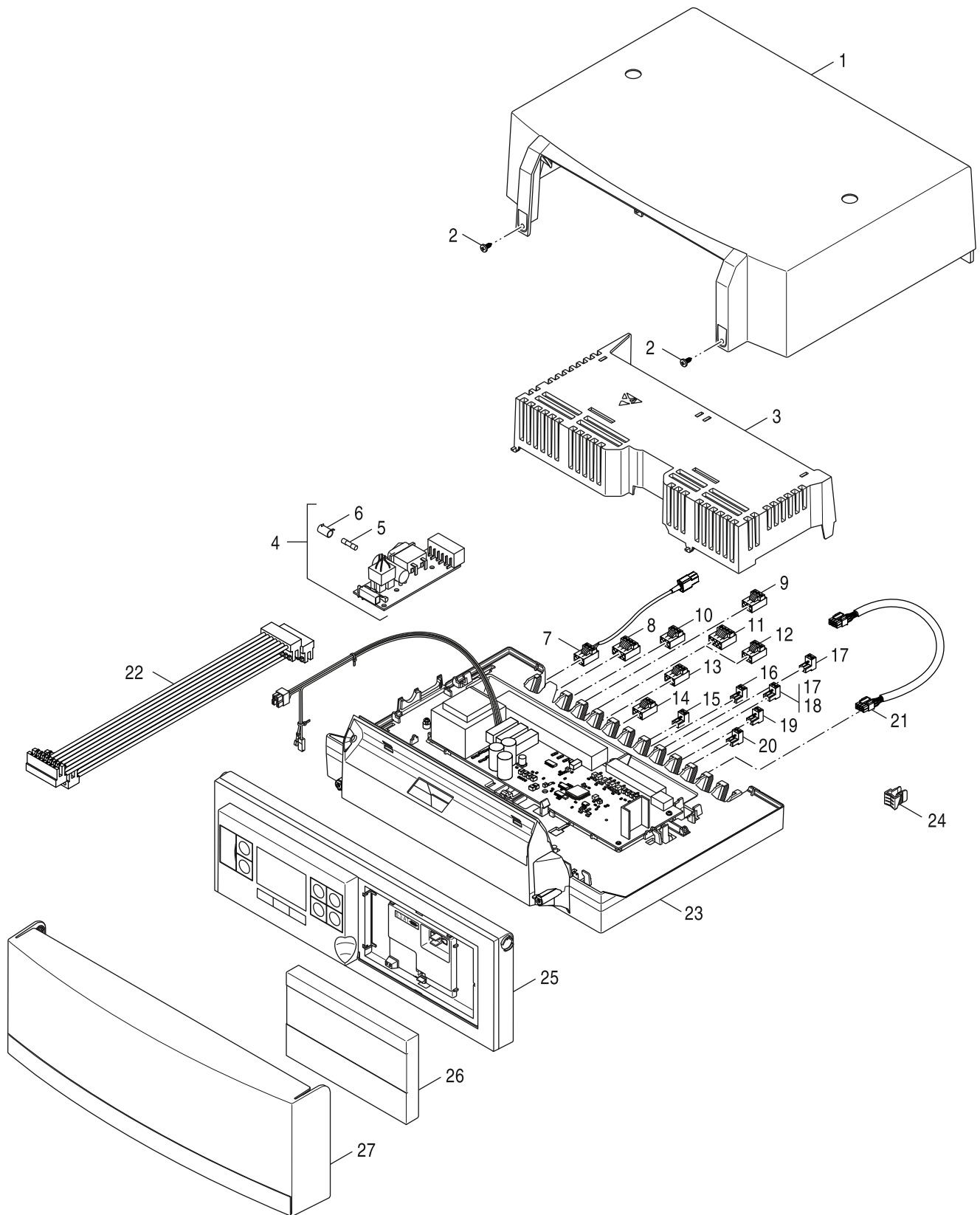

8738891425.ad.RS

**9A**  
MC40  
MC40  
MC40  
MC40  
MC40

**GB212 MC40, MC100  
15-50kW**

Pos	Bezeichnung Description Dénomination Descrizioni Benaming Descripción		GB212-15/5	GB212-15/5 IP	GB212-22/6	GB212-22/6 IP	GB212-30	GB212-30/6	GB212-30/9	GB212-40/10	GB212-50/10									Bemerkungen Remarks Remarques Osservazioni Opmerkingen Observaciones
1	Gehäuseoberteil blau everp	8 718 583 355	■	■	■	■	■	■	■	■	■									
2	Schraube M 3,5 x 12 (6x)	7 736 700 684	■	■	■	■	■	■	■	■	■									
3	Modulträger MC40 blau everp	8 718 583 354	■	■	■	■	■	■	■	■	■									
4	Leiterplatte SFA*2 S01 everp	8 718 583 353	■	■	■	■	■	■	■	■	■									
5	Sicherungseinsatz 5x20 6,3AT230V (10X)	8 718 578 518	■	■	■	■	■	■	■	■	■									
6	Sicherungshalter-Kappe everp	8 718 221 358 0	■	■	■	■	■	■	■	■	■									
7	Netzanschlussleitung Kaltgeräteest everp	6 302 393 1	■	■	■	■	■	■	■	■	■									
8	Anschlussklemme 4-pol orange 17B18 everp	8 718 590 270	■	■	■	■	■	■	■	■	■									
9	Anschlussklemme 3-pol Netz weiß everp	7 747 023 981	■	■	■	■	■	■	■	■	■									
10	Anschlussklemme 3-pol gelb everp	7 747 026 994	■	■	■	■	■	■	■	■	■									
11	Anschlussklemme 4-pol viol. SH I Mischer	7 747 023 966	■	■	■	■	■	■	■	■	■									
12	Anschlussklemme 3-pol.PS Pumpe grau ever	7 747 023 985	■	■	■	■	■	■	■	■	■									
13	Anschlussklemme 3-pol. PZ Pumpe violett	7 747 023 986	■	■	■	■	■	■	■	■	■									
14	Anschlussklemme 3-pol. PH grün everp	7 747 023 983	■	■	■	■	■	■	■	■	■									
15	Anschlussklemme 2-pol WA maigrün everp	7 747 023 154	■	■	■	■	■	■	■	■	■									
16	Anschlussklemme 2-pol R5 blau everp	7 747 027 014	■	■	■	■	■	■	■	■	■									
17	Anschlussklemme 2-pol grau FW	7 747 026 992	■	■	■	■	■	■	■	■	■									
18	Anschlussklemme 2-pol toro EV Klemme	7 747 026 991	■	■	■	■	■	■	■	■	■									
19	Anschlussklemme 2-pol. orang RC everp	7 747 023 151	■	■	■	■	■	■	■	■	■									
20	Anschlussklemme 2-pol. weiss everp	7 747 023 129	■	■	■	■	■	■	■	■	■									
22	Verbindungskabel 155mm 7-adrig everp	8 718 583 349	■	■	■	■	■	■	■	■	■									
23	Leiterplatte MC40 mit Kabelbaum V1 everp	8 718 589 046	■	■	■	■	■	■	■	■	■									
24	Zugentlastung f. Regelgerät (10x) everp	8 718 583 348	■	■	■	■	■	■	■	■	■									
25	Bedieneinheit MC40 S03 LCD weiss everp	8 718 590 594	■	■	■	■	■	■	■	■	■									
26	Blindabdeckung BC weiß everp	8 718 583 350	■	■	■	■	■	■	■	■	■									
27	Gehäuse Klarsichthaube everp	8 718 583 357	■	■	■	■	■	■	■	■	■									

**GB212 MC40, MC100  
15-50kW**

MC40  
MC40  
MC40  
MC40  
MC40  
MC40

**9A**

**Ersatzteilliste**  
Spare parts list

**Liste des pièces de rechange**  
Lista parti di ricambio

**Onderdelenlijst**  
Lista de repuestos

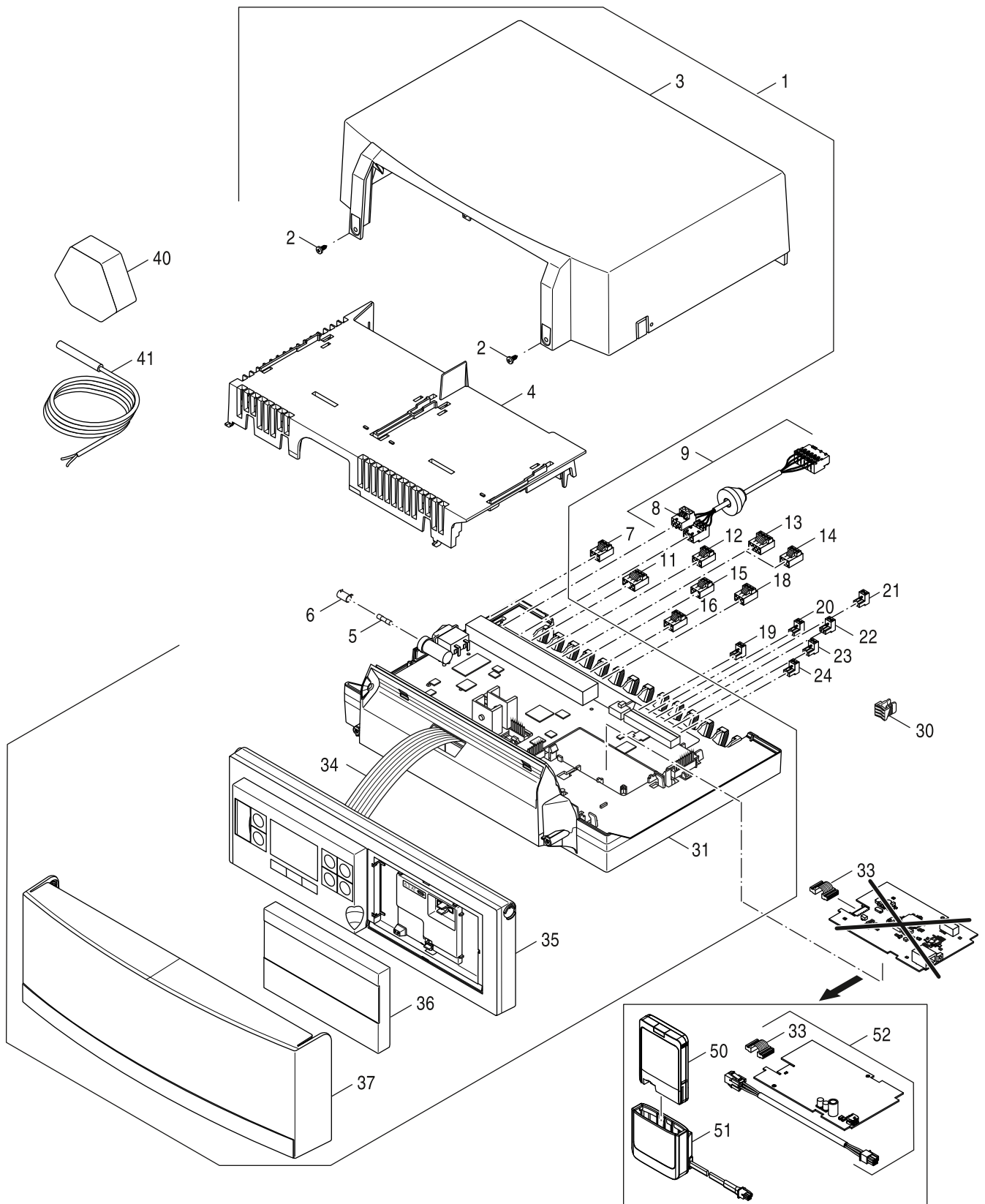

8738891813.ae.RO

**9B**  
MC100i  
MC100i  
MC100i  
MC100i  
MC100i

**GB212 MC40, MC100**  
**15-50kW**



<b>Übersetzungsliste</b> <b>List of translations</b>		<b>Liste des traductions</b> <b>Traduzione delle descrizioni</b>		<b>Vertalinglijst</b> <b>Lista de traducciones</b>	
Pos	Description	Denomination	Descrizione	Benaming	Descripción
1	<b>Element of construction</b>	<b>Groupe de construction</b>	<b>Gruppo di costruzione</b>	<b>Montagegroep</b>	<b>Grupo de construcción</b>
1	Pipe 5sec VK	Tube VK	Tubo VK	Buis VK	Tubo VK
1	Pipe 6sec VK	Tube VK	Tubo VK	Buis VK	Tubo VK
1	Pipe 9sec VK	Tube VK	Tubo VK	Buis VK	Tubo VK
1	Pipe 10 sec VK	Tube VK	Tubo VK	Buis VK	Tubo VK
2	Nipple Barrel D32,5 R1 1/4	Double mamelon	Doppio capezzolo	Dubbele nippel	Conexión
3	Seal D42xD58x4	Joint	Guarnizione	Pakking	Junta
4	Pipe drain	Évacuation des condensats	Scarico condensa	Condensafvoer	Drenaje de condensado
5	Nut PG29	Contre-écrou	Controdado	Borgmoer	Contratuercá
6	Flue outlet concentric 80/125 gas V2 SP	FUMIS BUSE CHAUD CONCEN 80/125 V2	Trochetto fumi conc. 80/125 V2	Conc. rookgasaansluiting voor 80/125 V2	Salida de gases concéntrica 80/125 V2
7	Flue outlet concentric 80/125 gas V1 SP	FUMIS BUSE CHAUD CONCEN 80/125 V1	Trochetto fumi conc. 80/125	Conc. rookgasaansluiting voor	Salida de gases concéntrica 80/125
8	lips seal d80 PerOxyd (5x)	Joint a levre DN80 peroxyde (5x)	Guarniz. ad anello spigolo tenutaDN80 5x	Lippenafdichting DN80 PerOxid (5x)	Junta DN80 PerOxyd (5x)
9	Shaped seal DN125	Joint à lèvres DN125	Guarn. anello + spig. tenuta DN125	Lipring DN125	Junta bilabial DN125
10	Lip seal DN80	Joint DN80	Guarnizione DN80	Lipring DN80	Junta DN80
11	Lip seal DN125	Joint DN125	Guarnizione DN125	Lipring DN125	Junta DN125
12	Syphon	Siphon	Sifone	Sifon	Sifón
12	Siphon	Siphon	Sifone	Sifon	Sifón
13	Cover - Service Access	Couvercle	Coperchio	Afdekdeksel	Tapa
14	Sealing (5x)	Joint DN 18 (5x)	Guarn. anello con spig. di ten. DN18(5x)	Dichtingsring (5x)	Junta DN18 (5x)
15	Plug G 1	BOUCHON G1	Tappo	Stop	Tapon G1
16	Gasket D33x44x2mm	Joint D33x44x2mm	Guarnizione	Pakking	Junta
17	O-ring D28x3mm 70EPDM/281 pckd	Joint torique D28x3 70EPDM/281	O-ring	O-ring	Anillo tórico
18	Spring d=38,2/28	Pince à ressort d=38,2/28	Molla	Veerklem	Clip de la primavera d=38,2/28
19	SENSOR G1/4 45mm sp	Sonde temperature G1/4 45mm	SENSOR G1/4 45mm	Voeler G1/4 45mm	Sensor individual G1/4 45mm
20	Hexagon nut DIN6923 M8 A3K (10x)	Ecrou hexagonal DIN6923 M8 A3K (10x)	Dado esagonale DIN6923 M8 A3K (10x)	Zeskantmoer DIN6923 M8 A3K (10x)	Tuerca hexagonal DIN6923 M8 A3K (10x)
23	Switch PressureTyp 505.91570 packed	Transmetteur pression typ 505.91570	Transmetteur pression Typ 505.91570 verp	TRANSMETTEUR PRESSION TYP 505.91570	presostato de Seguridad GB312
24	stud DIN939 M8x20 (3x)	goujon fileté DIN939 M8x20 (3x)	prigioniero DIN939 M8x20 (3x)	tapeind DIN939 M8x20 (3x)	Tornillo prisionero DIN939 M8x20 (3x)
25	Lip seal 29,8 x 6,1 (5x)	Joint 29,8 x 6,1 (5x)	Guarnizione 29,8 x 6,1 (5x)	Lipring 29,8 x 6,1 (5x)	Junta 29,8 x 6,1 (5x)
26	Boiler_block L-Design 30/9 V3 spare	Bloc chaudière L-Design 30/9 V3	Corpo caldaia L-Design 30/9 V3	Ketelblok L-Design 30/9 V3	Cuerpo de caldera L-Design 30/9 V3
26	Boiler_block L-Design 40/10 V3 spare	Bloc chaudière L-Design 40/10 V3	Corpo caldaia L-Design 40/10 V3	Ketelblok L-Design 40/10 V3	Cuerpo de caldera L-Design 40/10 V3
26	Boiler_block L-Design 30/6 V2 spare	Bloc chaudière L-Design 30/6 V2	Corpo caldaia L-Design 30/6 V2	Ketelblok L-Design 30/6 V2	Cuerpo de caldera L-Design 30/6 V2
26	Boiler_block L-Design 50/10 V2 spare	Bloc chaudière L-Design 50/10 V2	Corpo caldaia L-Design 50/10 V2	Ketelblok L-Design 50/10 V2	Cuerpo de caldera L-Design 50/10 V2

<b>Übersetzungsliste</b> <b>List of translations</b>		<b>Liste des traductions</b> <b>Traduzione delle descrizioni</b>		<b>Vertalinglijst</b> <b>Lista de traducciones</b>	
Pos	Description	Denomination	Descrizione	Benaming	Descripción
26	Boiler block L-Design 15/5N sp	Bloc chaudière L-Design 15/5 N	Corpo caldaia L-Design 15/5 N	Ketelblok L-Design 15/5 N	Cuerpo de caldera L-Design 15/5 N
26	Boiler block L-Design 22/6N sp	Bloc chaudière L-Design 22/6N	Corpo caldaia L-Design 22/6 N	Ketelblok L-Design 22/6 N	Cuerpo de caldera L-Design 22/6 N
27	Sensor boiler G1/4 45mm sp	Sonde chaudiere g1/4 45mm	Sonda Caldaia G1/4 45mm	Ketelvoeler G(B)135 G1/4 45mm	Sensor de caldera G1/4 45mm
28	Sample point cap	Capot de protection	Calotta	Beschermkap	Capuchón protector
29	Plug	Bouchon	Tappo	Stop	Tapon
30	Screw pan head ST3,9x20 A2K everp (10x)	Vis ST3,9x20 A2k (10x)	Vite St3,9x20 A2k (10x)	Schroef met vlakke kop ST3,9x20 A2K(10x)	Tornillo ST3,9x20 A2k (10x)
31	screw ST3,9X16 (6x)	vis ST3,9X16 (6x)	vite ST3,9X16 (6x)	schroef ST3,9X16 (6x)	tornillo ST3,9X16 (6x)
	Tube set DN20 DN20 (3m)	Tuyau DN20 (3m)	Tube flessibile DN20 (3m)	Slang DN20 (3m)	Manguera DN20 (3m)
	Lock nut KM11 M55x2 packed	Contre-écrou KM11 M55x2	Controdado KM11 M55x2	Borgmoer KM11 M55x2	Contratuercas KM11 M55x2
<b>2</b>	<b>Element of construction</b>	<b>Groupe de construction</b>	<b>Gruppo di costruzione</b>	<b>Montagegroep</b>	<b>Grupo de construccion</b>
1	Panel blue	Frontal	Piastra	Plaat	Placa
2	Badge "Buderus	Plaque signalétique	Targhetta caldaia	Typeplaat	Placa del aparato
4	Hood outside blue 5-6 Gld	Hotte 5-6 Gld	Cappuccio	Kap	Capó
4	Hood outside blue 9-10 Gld	Hotte 9-10 Gld	Cappuccio	Kap	Capó
6	Insulation front	Isolation avant	Coibentazione anteriore	Isolatie Voor	Aislamiento delante
7	Panel le/ri blue 5-6 Gld	Panneau latéral	Parete laterale	Zijwand	Pared lateral
7	Panel ri/le blue 9/10 Gld	panneau latéral gauche 9/10 Gld bleu	Parete laterale sinistra	zijwand Links 9/10Gld blauw	Pared lateral izquierda 9/10 Gld azul
8	Insulation Block 5sec	Isolation bloc	Coibentazione bloco	isolatie blok	Aislamiento
8	Insulation Block 6sec	Isolation bloc	Coibentazione bloco	isolatie blok	Aislamiento
8	Insulation Block 9Gld	Isolation bloc	Coibentazione bloco	isolatie blok	Aislamiento
8	Insulation Block 10sec	Isolation bloc	Coibentazione bloco	isolatie blok	Aislamiento
9	Pan-head screw ST3,9x9,5 A3T (10x)	Vis à tête plate ST3,9 (10x)	Vite a testa piana ST3,9x9,5 (10x)	Schroef met vlakke kop ST3,9x9,5 (10x)	Tornillo avellanado ST3,9x9,5 (10x)
10	Installation_kit panel front	Kit de montage frontal	Set di montaggio piastra	Montageset plaat	Juego de montaje placa
11	Insulation Clamp (10x)	Ressorts de retenue d 0.8 (10x)	Molla di tenuta (10x)	Borgveer (10x)	Muelle tensor para aislamientos (10x)
12	Foot M10x51 (4x)	Pieds réglables M10x51 (4x)	Piedini regolabili M10x51 (4x)	Voetjes Boiler HP-270-1	Patas regulables M10x51 (4x)
13	Hose D46 / 4019	Entrée de câble	Ingresso cavi	Kabeldoorvoer	Entrada de cable
	Insulation front	Isolation avant	Isolamento termico anteriore	Isolatie voor	Aislamiento térmico delante
	Insulation 30-40 kW left/right	Isolation ga/dr	Coibentazione si/de	Isolatie li/re	Aislamiento iz/de
	Insulation 15-22kW top	Isolation haut	Coibentazione sopra	Isolatie boven	Aislamiento amba
	Insulation 30-40kW top	Isolation haut	Coibentazione sopra	Isolatie boven	Aislamiento amba
	Insulation 15-22kW left/right	Isolation ga/dr	Coibentazione si/de	Isolatie li/re	Aislamiento iz/de
<b>3</b>	<b>Element of construction</b>	<b>Groupe de construction</b>	<b>Gruppo di costruzione</b>	<b>Montagegroep</b>	<b>Grupo de construccion</b>

Übersetzungsliste List of translations		Liste des traductions Traduzione delle descrizioni		Vertalinglijst Lista de traducciones	
Pos	Description	Denomination	Descrizione	Benaming	Descripción
1	Fitting T-Piece G1" with sleeve G3/4" VL	Raccord en T	Raccordo a T	T-stuk	Pieza en T
1	Fitting G11/2 with sleeve G3/4 VL SP	Taccord en T G11/2/manchon G3/4 VL	Raccordo a T G11/2/manicotto G3/4 VL	T-stuk G11/2/mof G3/4 VL	Pieza en T G11/2/manguito G3/4 VL
1	T-Piece G1 with sleeve G3/4 VL V3 sp	Raccord en T G1 Manchon G3/4 V3	Raccordo a T G1 Manicotto G3/4 V3	T-stuk G1 Mof G3/4 V3	Pieza en T G1 Manguito G3/4 V3
2	Seal D27x38x2 DVGW packed	Joint D27x38x2mm C4400 Klinger SIL	Guarnizione 27x38x2mm C4400 Klinger SIL	Dichting 27x38x2mm voor gasbuis	Junta D27x38x2mm DVGW verde
2	Gasket D32x44x2mm C4400 Klinger SIL, pck	Joint D32x44x2mm	Guarnizione	Pakking D32x44x2	Junta
2	Seal Set D32x44x2mm AFM34 (5 pc)	Kit d'étanchéité D32x44x2 AFM34 (5 pces)	Set guarnizioni D32x44x2 AFM34 (5 pz.)	Afdichtingsset D32x44x2mm AFM34 (5 St)	Juego de juntas D32x44x2 AFM34 5 ud.
4	Gasket D17x24x2mm C4400 Klinger SIL,	Joint D17x24x2mm C4400 Klinger SIL, vert	Guarnizione	Afdichting	Junta
5	Fitting T-piece G1" with sleeve G1/4	Raccord en T	Raccordo a T	T-stuk	Pieza en T
5	T-Stück G1 with O-Ring RL everp	Taccord en T G1 RL	Raccordo a T G1 RL	T-stuk G1 RL	Pieza en T G1 RL
5	Fitting G11/2 with sleeve G1/4 RL spare	Taccord en T G11/2/manchon G1/4 RL	Raccordo a T G11/2/manicotto G1/4 RL	T-stuk G11/2/mof G1/4 RL	Pieza en T G11/2/manguito G1/4 RL
6	Sealing ring D32x44x2mm (5x) EPDM	Joint d'étanchéité D32x44x2mm EPDM	Guarnizione D32x44x2mm EPDM	pakking D32x44x2mm EPDM	junta D32x44x2mm EPDM
6	Gasket D21x30x2mm AFM 34 (5x)	Joint D21x30x2mm AFM 34 (5x)	Guarnizione D21x30x2mm AFM 34 (5x)	pakking D21x30x2mm AFM 34 (5x)	Junta D21x30x2mm AFM 34 (5x)
6	O-ring 29,82x2,62 EPDM (x5) packed	Joint torique 37x3 EPDM (x5)	O-ring 29,82x2,62 EPDM (x5)	O-ring 29,82x2,62 EPDM (x5)	Anillo tórico 29,82x2,62 EPDM (x5)
6	O-ring 37x3 EPDM (5x) spare	Joint torique 37x3 EPDM (5x)	O-ring 37x3 EPDM (5x)	O-ring 37x3 EPDM (5x)	Anillo tórico 37x3 EPDM (5x)
7	Cap G1 1/2x16 with Gasket	Bouchon G1 1/2x16 avec joint	Tappo	Beschermkapje	Tapa
7	Cover G1" packed	Capuchon G1"	Tappo G1"	Kapje G1"	Tapa G1"
8	Nipple double G1x31 with o-ring	Double mamelon	Doppio capezzolo	Dubbele nippel	Conexión
9	Valve Fill and drain G1xG3/4 packed	robinet remplissage et vidange G1xG3/4	rubinetto di carico e scarico	vul- en aftapkraan	llave de llenado y vaciado
10	Tube flute steel DN16 1000mm packed	Flexible métallique DN16 1000mm	Tubo metallico ondulado DN16 1000mm	Flexibele leiding DN16 1000mm	Manguera ondulada de metal DN16 1000mm
11	Cap valve flat sealing 3/4x3/4	Soupape	Tappo della valvola	Ventieldop	Tapa de la válvula
12	Accessory base plate expansion tank	Plaque de jonction vase d'expansion	Lamierino vaso di espansione	Houderplaat expansievat	Placa de unión vaso de expansión
13	O-ring 22x2,5 70EPDM/281 (5x)	Joint torique 22x2,5 70EPDM/281 (5x)	O-ring 22x2,5 70EPDM/281 (5x)	O-ring 22x2,5 70EPDM/281 (5x)	Anillo tórico 22x2,5 70EPDM/281 (5x)
14	Seal D19x24.3x2mm AFM34 (5x)	Joint D19x24,3x2mm AFM34 (5x)	Guarnizione D19x24,3x2mm AFM34 (5x)	pakking D19x24,3x2mm AFM34 (5x)	Junta D19x24,3x2mm AFM34 (5x)
15	Fitting Connection G1-G1	Raccord sonde sanitaire	Serraggio a vite	Schroefkoppeling	Unión roscada
16	Seal D24x30,5x2 AFM34 (1x) packed	Joint D24x30,5x2 AFM34 (1x)	Guarnizione D24x30,5x2 AFM34 (1x)	Pakking D24x30,5x2 AFM34 (1x)	Junta D24x30,5x2 AFM34 (1x)
17	Double nipple G1x33 flat sealing	Nipple double G1x33mm (étanche)	Nipples doppio G1x33mm (a guarnizione pi)	Dubbele nippel	Racor doble G1x33 cn junta plana
18	KSS Manifolds	Collecteur KSS	KSS Collettori	KSS Manifolds	KSS Colectores
19	Pipe Connection KSS 75x223	Tuyau de raccordement KSS	Tubo di raccordo KSS	Aansluitbuis KSS	Tubería de conexión KSS
19	Pipe BSS2 /BSS5 G3/4	Tube BSS2 /BSS5 G3/4	Tubo BSS2 /BSS5 G3/4	Buis BSS2 /BSS5 G3/4	Tubo BSS2 /BSS5 G3/4
20	Gasket D17x24x2mm C4400 Klinger SIL,	Joint D17x24x2mm C4400 Klinger SIL, vert	Guarnizione	Afdichting	Junta
20	Gasket D17x24x2 AFM34 (x10)	Joint D17x24x2 AFM34 (10x)	Guarnizione D17x24x2 AFM34 (10x)	Afdichting D17x24x2 AFM34	Junta D17x24x2 AFM34 (10x)
21	Insulation KSS distributor	Isolation	Coibentazione	Isolatie	Aislamiento



Übersetzungsliste List of translations		Liste des traductions Traduzione delle descrizioni		Vertalinglijst Lista de traducciones	
Pos	Description	Denomination	Descrizione	Benaming	Descripción
22	Air_vent automatic purging system 3/8"	Pot de ventilateur 3/8"	Valvola di sfianto 3/8"	Ontluchtingsdeksel 3/8"	Separador de aire 3/8"
23	Connector pipe RK G1 1/4" 142x206	Tuyau de raccordement RK	Tubo di raccordo RK	Aansluitbuis RK	Tubería de conexión RK
23	Pipe RK G11/2 cpl	Tube RK G1 1/2	Tubo RK G1 1/2	Buis RK G1 1/2	Tubo RK G1 1/2
24	Connector pipe VK G1 1/4" 222x206	Tuyau de raccordement VK	Tubo di raccordo VK	Aansluitbuis VK	tubería de conexión VK
24	Pipe VK G11/2 cpl	Tube VK G1 1/2	Tubo VK G1 1/2	Buis VK G1 1/2	Tubo VK G1 1/2
26	Locking cap G3/4 m. Gasket	Clapet de fermeture G3/4 avec joint	Calotta	Cap	Tapón
27	SENSOR G1/4 45mm sp	Sonde temperature G1/4 45mm	SENSOR G1/4 45mm	Voeler G1/4 45mm	Sensor individual G1/4 45mm
	Logafix Membran-sec.val.1/2" 3,0 bar	Soupape de securite logafix 1/2 3.0 bar			
	Pressure gauge for closed conn.,	Manometre pr install fermees 2.5 bar	Manometro 2,5bar 63mm AE D3/8"U	Manometer 2,5bar 63mm AE D3/8"U	Manómetro 2,5bar 63mm AE D3/8"U
<b>5</b>	<b>Element of construction</b>	<b>Groupe de construction</b>	<b>Gruppo di costruzione</b>	<b>Montagegroep</b>	<b>Grupo de construccion</b>
1	Burner VM1.0 15kW G20 V2	brûleur gaz VM1.0 15kW G20 V2	bruciatore a gas VM1.0 15kW G20 V2	brander VM1.0 15kW G20 V2	quemador de gas VM1.0 15kW G20 V2
1	Burner VM1.0 22kW G20 V2	brûleur gaz VM1.0 22kW G20 V2	bruciatore a gas VM1.0 22kW G20 V2	brander VM1.0 22kW G20 V2	quemador de gas VM1.0 22kW G20 V2
1	Burner VM1.0 30kW G20 V2	brûleur gaz VM1.0 30kW G20 V2	bruciatore a gas VM1.0 30kW G20 V2	brander VM1.0 30kW G20 V2	quemador de gas VM1.0 30kW G20 V2
1	Burner VM1.0 40kW G20 V2	brûleur gaz VM1.0 40kW G20 V2	bruciatore a gas VM1.0 40kW G20 V2	brander VM1.0 40kW G20 V2	quemador de gas VM1.0 40kW G20 V2
1	Burner VM1.0 15kW G25 V2	brûleur gaz VM1.0 15kW G25 V2	bruciatore a gas VM1.0 15kW G25 V2	brander VM1.0 15kW G25 V2	quemador de gas VM1.0 15kW G25 V2
1	Burner VM1.0 22kW G25 V2	brûleur gaz VM1.0 22kW G25 V2	bruciatore a gas VM1.0 22kW G25 V2	brander VM1.0 22kW G25 V2	quemador de gas VM1.0 22kW G25 V2
1	Burner VM1.0 30kW G25 V2	brûleur gaz VM1.0 30kW G25 V2	bruciatore a gas VM1.0 30kW G25 V2	brander VM1.0 30kW G25 V2	quemador de gas VM1.0 30kW G25 V2
1	Burner VM1.0 40kW G25 V2	brûleur gaz VM1.0 40kW G25 V2	bruciatore a gas VM1.0 40kW G25 V2	brander VM1.0 40kW G25 V2	quemador de gas VM1.0 40kW G25 V2
1	Gasburner VM1.0 30kW/6sec G20 spare	brûleur gaz VM1.0 30kW/6 G20	bruciatore a gas VM1.0 30kW/6 G20	brander VM1.0 30kW/6Gld G20	quemador de gas VM1.0 30kW/6 G20
1	Gasburner VM1.0 50kW/10sec G20 spare	brûleur gaz VM1.0 50kW/10 G20	bruciatore a gas VM1.0 50kW/10 G20	brander VM1.0 50kW/10 G20	quemador de gas VM1.0 50kW/10 G20
1	Gasburner VM1.0 30kW/6sec G25 spare	brûleur gaz VM1.0 30kW/6 G25	bruciatore a gas VM1.0 30kW/6 G25	brander VM1.0 30kW/6 G25	quemador de gas VM1.0 30kW/6 G25
1	Gasburner VM1.0 50kW/10sec G25 spare	brûleur gaz VM1.0 50kW/10 G25	bruciatore a gas VM1.0 50kW/10 G25	brander VM1.0 50kW/10 G25	quemador de gas VM1.0 50kW/10 G25
5	Service-Set VM1.0 everp	Set de service VM1.0	Imballato VM1.0	Service set VM1.0	Conjunto de servicio VM1.0
	Conversion_kit G20/G25	kit de transformation G20/G25	kit conversione G20/G25	gasombouwset G20/G25	kit de transformación G20/G25
	Conversion kit VM1.0 50/10 G31 LPG V2	Kit de transformation de gaz GB212-50 v2	Trasformazione GPL VM1.0 50/10 G31 V2	Ombouwset propaan GB212-50v2	
	Conversion kit VM1.0 30/6 G31 LPG V2	Kit de transformation de gaz GB212-30 v2	Trasformazione GPL VM1.0 30/6 G31 V2	Ombouwset propaan GB212-30v2	Kit transformación propano KBR30 V2
	Conversion_kit VM1.0 15kW V2	Kit de conversion propaan VM1.0 15 kW V2	Kit conversione gas GB212-15	Vloeibaargasombouwset VM1.0 15 kW V2	Kit transformación propano KBR15
	Conversion_kit VM1.0 22kW V2	Kit de conversion propane VM1.0 22kW V2	Trasformazione GPL VM1.0 22kW V2	Vloeibaargasombouwset VM1.0 22kW V2	Kit transformación propano KBR22
	Conversion_kit VM1.0 30kW V2	Kit de conversion propaan VM1.0 30kW V2	Trasformazione GPL VM1.0 30kW V2	Vloeibaargasombouwset VM1.0 30kW V2	
	Conversion_kit VM1.0 40kW V2	Kit de conversion propaan VM1.0 40kW V2	Trasformazione GPL VM1.0 40kW V2	Vloeibaargasombouwset VM1.0 40kW V2	Kit transformación propano KBR40
<b>6</b>	<b>Element of construction</b>	<b>Groupe de construction</b>	<b>Gruppo di costruzione</b>	<b>Montagegroep</b>	<b>Grupo de construccion</b>
1	burner rod VM1.0 15/VM1.1 22kW	rampe de combustion VM1.0 15/VM1.1 22kW	torcia del bruciatore VM1.0 15/ VM1.1 22k	staafbrander VM1.0 15/VM1.1 22kW	barra combustible VM1.0 15/ VM1.1 22kW

Übersetzungsliste List of translations		Liste des traductions Traduzione delle descrizioni		Vertalinglijst Lista de traducciones	
Pos	Description	Denomination	Descrizione	Benaming	Descripción
1	burner rod VM1.0 22/VM1.1 30kW	rampe de combustion VM1.0 22/VM1.1 30kW	torcia del bruciatore VM1.0 22/ VM1.1 30k	staafrander VM1.0 22/VM1.1 30kW	barra combustible VM1.0 22/ VM1.1 30kW
1	burner rod 30kW	rampe de combustion 30kW	torcia del bruciatore 30kW	staafrander 30kW	barra combustible 30kW
1	burner rod 40/50kW	rampe de combustion 40/50kW	torcia del bruciatore 40/50kW	staafrander 40/50kW	barra combustible 40/50kW
2	Seal Burner tube	JOINT BRULEUR	Guarnizione Raccordo bruciatore	Dichting voor branderstaaf	Junta cañón quemador
3	Screw Ejot Altracs M6x14 (10x)	vis Ejot Altracs M6x14 (10x)	Vite Ejot Altracs M6x14 (10x)	schroef Ejot Altracs M6x14 (10x)	tornillo Ejot Altracs M6x14 (10x)
4	Insulation burner flange 15-40kW	Isolation bride de bruleur 15-40kW	Coibentazione Flangia 15-40kW	Isolatie Aansluitflens 15-40kW	Aislamiento Brida Quemador 15-40kW
5	Ceramic adhesives Thermofix tube 115gr	Céramique COLLE THERMOFIX TUBE 115 GR.	Ceramica Adesivo Thermofix 115gr.	Keramiek Lijm Thermofix 115gr.	Pegamento cerámico tubo de 115 gr.
6	Ignition 15-50kW spare part	électrode d'allumage VM1.0 15-50kW	elettrodo di accensione VM1.0 15-50kW	ontstekingselektrode VM1.0 15-50kW	electrodo de encendido VM1.0 15-50kW
7	Screw DIN7985 M4x10 8.8A3K (4x)	Vis à tête bombée DIN 7985 M4x10 8.8A3K	Vite DIN7985 M4x10 8.8A3K (4x)	schroef DIN7985 M4x10 8.8A3K (4x)	tornillo DIN7985 M4x10 8.8A3K (4x)
8	Seal electrode (2x)	Joint électrode (2x)	Guarnizione Elettrodo (2x)	Pakking elektrode (2x)	Junta electrodo (2x)
9	Electrode ionisation VM1.0 15-50kW everp	électrode de contrôle VM1.0 15-50kW	elettrodo di controllo VM1.0 15-50kW	ionisatie-elektrode VM1.0 15-50kW	electrodo de control VM1.0 15-50kW
10	Glass_sight M16x1 kpl	verre du viseur M16x1	vetrino M16x1	kijkglas M16x1	mirilla M16x1
11	Pressure Test Point G1/8	CAPTEUR DE PRESSION GB402 G1/8"	Presa pressione G1/8"	Drukmeetnippel G1/8"	Juego toma presiones G1/8
12	O-ring 253,37 x 5,33	Joint torique 253,37 x 5,33	Anello tenuta 253,37 x 5,33	O-ring 253,37 x 5,33	Anillo tórico 253,37 x 5,33
13	Switch bimetal 130°C packed	Interrupteur 130°C	Interruttore 130°C	Schakelaar 130°C	Limitador 130°C"
<b>7</b>	<b>Element of construction</b>	<b>Groupe de construction</b>	<b>Gruppo di costruzione</b>	<b>Montagegroep</b>	<b>Grupo de construccion</b>
1	Fan PEBM D118 AC230 50 070W PWM MC spare	Ventilateur PEBM D118 AC230 50 070W PWM	ventilatore PEBM D118 AC230 50 070W PWM	Ventilator PEBM D118 AC230 50 070W PWM	Ventilador PEBM D118 AC230 50 070W PWM
1	Fan P EBM D118 AC230 50 120W PWM spare	ventilateur EBM D118 AC230 50 120W	ventilatore EBM D118 AC230 50 120W	ventilator EBM D118 AC230 50 120W	ventilador EBM D118 AC230 50 120W
2	Seal (Fan)	Joint (Ventilateur)	Guarnizione (Ventilatore)	Pakking (Ventilator)	Junta (Ventilador)
3	Screw Ejot Altracs M6x14 (10x)	vis Ejot Altracs M6x14 (10x)	Vite Ejot Altracs M6x14 (10x)	schroef Ejot Altracs M6x14 (10x)	tornillo Ejot Altracs M6x14 (10x)
4	Screw 40x8/7 TORX (10x)	Vis 40x8/7 TORX (10x)	Vite 40x8/7 TORX (10x)	Schroef 40x8/7 TORX (10x)	Tornillo 40x8/7 TORX (10x)
5	Gasket Venturi casing	Joint carter Venturi	Guarnizione Venturi Involucro	Pakking Venturi-behuizing	Junta carcasa Venturi
6	Venturi housing	Venturi Carter	Venturi Involucro	Venturi behuizing	Venturi carcasa
7	Screw M5x33 (10x)	vis (10x)	Vite (10x)	Schroef gasregelblok (10 x)	tornillo (10x)
8	Sealing set (2x5x)	Lot de joints plats (2x5x)	Set guarn.piatte l'ugello dell'aria(2x5x)	Dichtingsringen set (2x5x)	Juego de juntas (2x5x)
9	Valve Gas SIT848 Sigma 3/4" flw adjuster	Soupape gaz SIT848 3/4" flw adjuster	Rubinetto gas SIT848 3/4" flw adjuster	gasklep SIT848 3/4" flw adjuster	válvula de gas SIT848 3/4" flw adjuster
10	Gas_valve conversion set 15kW G20/G25	kit de transformation 15kW G20/G25	kit di conversione 15kW G20/ G25	ombouwset 15kW G20/G25	kit de transformación 15kW G20/G25
11	Gasket D17x24x2 AFM34 (x10)	Joint D17x24x2 AFM34 (10x)	Guarnizione D17x24x2 AFM34 (10x)	Afdichting D17x24x2 AFM34	Junta D17x24x2 AFM34 (10x)
12	O-ring set orifice (5x)	Lot de joints toriques injecteur gaz	Set O-ring dell'ugello del gas	O-ring set restrictie	Juego juntas tóricas para orificio (5x)
13	Gas nozzle 5,05 mm	Injecteur gaz 5.05 mm	Iniettore del gas 5,05 mm	Gasinspuitter 5,05 mm	Tobera 5,05 mm
13	Orifice 5.90 [mm]	Injecteur gaz 5,90 [mm]	Ugello del gas 5,90 [mm]	Gasinspuitter 5,90 [mm]	Tobera de gas 5,90 [mm]
13	Nozzle D3,8	injecteur D3,8	Ugello D3,8	sputstuk D3,8	tobera D3,8

<b>Übersetzungsliste</b> <b>List of translations</b>		<b>Liste des traductions</b> <b>Traduzione delle descrizioni</b>		<b>Vertalinglijst</b> <b>Lista de traducciones</b>	
Pos	Description	Denomination	Descrizione	Benaming	Descripción
13	Nozzle D7,8	injecteur D7,8	Ugello D7,8	spuitstuk D7,8	tobera D7,8
13	Nozzle D2,6	injecteur D2,6	Ugello D2,6	spuitstuk D2,6	tobera D2,6
13	Nozzle D3,35	injecteur D3,35	Ugello D3,35	spuitstuk D3,35	tobera D3,35
13	Nozzle D3,95	injecteur D3,95	Ugello D3,95	spuitstuk D3,95	tobera D3,95
13	Nozzle D4,65	injecteur D4,65	Ugello D4,65	spuitstuk D4,65	tobera D4,65
13	Nozzle D8,1 spare part	injecteur D8,1	ugello D8,1	inspuitter D8,1	tobera D8,1
13	Nozzle D4,8 spare part	injecteur D4,8	ugello D4,8	inspuitter D4,8	tobera D4,8
14	Venturi 15kW	Injecteur d'air G20 et G25,15kW compl.	Venturi 15mm G20/G25/G31	Venturi 15kW	Tobera Venturi 15mm G20/G25/G31
14	Venturi 24/30kW (423.072A)	Injecteur air g20/g25 24/30 kW	Venturi	Venturi G20/25	Tobera Venturi 423.072A
14	Venturi	Injecteur d'air G20 et G25	Venturi 20,5mm G20/G25/G31	Venturi	Tobera Venturi 423.170A
14	Venturi element	Venturi	Venturi	Venturi	Venturi
15	Suction pipe	Tuyau d'aspiration du ventilateur	Tube di aspirazione del ventilatore	Luchtaanzuigpijp	Tube de aspiración de aire del
16	Pipe conn VM1.0 15kW	Raccordement 15kW	Raccordo 15kW	gasaansluiting 15kW	conexión de gas 15kW
16	Pipe conn pipe 22kW	Raccordement gaz 22kW	Raccordo gas 22kW	gasaansluiting 22kW	conexión de gas 22kW
16	Pipe conn 30kW	Raccordement gaz 30kW	Raccordo gas 30kW	gasaansluiting 30kW	conexión de gas 30kW
16	Pipe conn 40kW	Raccordement gaz 40kW	Raccordo gas 40kW	gasaansluiting 40kW	conexión de gas 40kW
16	Pipe conn VM1.0 15kW	Raccordement VM1.0 15kW	Raccordo VM1.0 15kW	gasaansluiting VM1.0 15kW	conexión de gas VM1.0 15kW
16	Pipe conn pipe VM1.0 22kW	Raccordement gaz VM1.0 22/30kW	Raccordo gas VM1.0 22/30kW	gasaansluiting VM1.0 22/30kW	conexión de gas VM1.0 22/30kW
16	Pipe conn VM1.0 30kW	Raccordement gaz VM1.0 30/9	Raccordo gas VM1.0 30/9	gasaansluiting VM1.0 30/9	conexión de gas VM1.0 30/9
16	Pipe conn VM1.0 40/50kW	Raccordement gaz VM1.0 40/50kW	Raccordo gas VM1.0 40/50kW	gasaansluiting VM1.0 40/50kW	conexión de gas VM1.0 40/50kW
17	Fan pipe	Tuyau d'aspiration ventilateur	Tube di aspirazione del ventilatore	Luchtaanzuigpijp	Tube de aspiración ventilador
18	Seal 50mm (5x)	Joint 50mm (5x)	Guarnizione 50mm (5x)	Pakking 50mm (5x)	Junta 50mm (5x)
<b>8</b>	<b>Element of construction</b>	<b>Groupe de construction</b>	<b>Gruppo di costruzione</b>	<b>Montagegroep</b>	<b>Grupo de construccion</b>
1	SAFe42*1 V4/S07	SAFe42*1 V4/S07	SAFe42*1 V4/S07	SAFe42*1 V4/S07	SAFe42*1 V4/S07
2	Housing Terminal cover SAFe	Couvercle safe GB402	Coperchio SAFe	Behuizing klemmenstrook SAFe	Carcasa cubre conexiones SAFE
3	Housing lower section SAFe	BOITIER ARRIERE SAFE	Involucro Parte inferiore SAFe	Behuizing achterwand SAFe	Carcasa posterior SAFe
4	Module BIM42 6201-V23 GB212 - 15 sp	module BIM42 6201-V23 GB212 - 15	Modulo BIM42 6201-V23 GB212 - 15	module BIM42 6201-V23 GB212 - 15	módulo BIM42 6201-V23 GB212 - 15
4	Module BIM42 6202-V23 GB212 - 22 sp	Module BIM42 6202-V23 GB212 - 22	Modulo BIM42 6202-V23 GB212 - 22	module BIM42 6202-V23 GB212 - 22	módulo BIM42 6202-V23 GB212 - 22
4	Module BIM42 6303-V23 GB212 - 30 sp	module BIM42 6303-V23 GB212 - 30	Modulo BIM42 6303-V23 GB212 - 30	module BIM42 6303-V23 GB212 - 30	módulo BIM42 6303-V23 GB212 - 30
4	Module BIM42 6204-V23 GB212 - 40 sp	module BIM42 6204-V23 GB212 - 40	Modulo BIM42 6204-V23 GB212 - 40	module BIM42 6204-V23 GB212 - 40	módulo BIM42 6204-V23 GB212 - 40
4	Module BIM42 6305-V23 GB212 - 50 sp	module BIM42 6305-V23 GB212 - 50	Modulo BIM42 6305-V23 GB212 - 50	module BIM42 6305-V23 GB212 - 50	módulo BIM42 6305-V23 GB212 - 50
4	Module BIM42 6211-V23 GB212-15 FG sp	module BIM42 6211-V23 GB212-15 FG	Modulo BIM42 6211-V23 GB212-15 FG	module BIM42 6211-V23 GB212-15 FG	módulo BIM42 6211-V23 GB212-15 FG

<b>Übersetzungsliste</b> <b>List of translations</b>		<b>Liste des traductions</b> <b>Traduzione delle descrizioni</b>		<b>Vertalinglijst</b> <b>Lista de traducciones</b>	
Pos	Description	Denomination	Descrizione	Benaming	Descripción
4	Module BIM42 6212-V23 GB212-22 FG sp	module BIM42 6212-V23 GB212-22 FG	Modulo BIM42 6212-V23 GB212-22 FG	module BIM42 6212-V23 GB212-22 FG	módulo BIM42 6212-V23 GB212-22 FG
4	Module BIM42 6313-V23 GB212-30 FG sp	module BIM42 6313-V23 GB212-30 FG	Modulo BIM42 6313-V23 GB212-30 FG	module BIM42 6313-V23 GB212-30 FG	módulo BIM42 6313-V23 GB212-30 FG
4	Module BIM42 6214-V23 GB212-40 FG sp	module BIM42 6214-V23 GB212-40 FG	Modulo BIM42 6214-V23 GB212-40 FG	module BIM42 6214-V23 GB212-40 FG	módulo BIM42 6214-V23 GB212-40 FG
4	Module BIM42 6315-V23 GB212-50 FG sp	module BIM42 6315-V23 GB212-50 FG	Modulo BIM42 6315-V23 GB212-50 FG	module BIM42 6315-V23 GB212-50 FG	módulo BIM42 6315-V23 GB212-50 FG
4	module BIM42 V22 - 30 spare part	module BIM42 V22 - 30	Modulo BIM42 V22 - 30	module BIM42 V22 - 30	módulo BIM42 V22 - 30
4	module BIM42 V22-30-FG spare part	module BIM42 V22-30-FG	Modulo BIM42 V22-30-FG	module BIM42 V22-30-FG	Módulo BIM42 V22-30-FG
5	Ignition Danfoss EBI V4 spare part	Transformateur allumage ebi danfoss v4	Dispositivo di accensione Danfoss EBI V4	Ontstekingsunit Danfoss EBI V4	Transformador de encendido EBI V4
6	Clip transformer EBI	Fixation	Clip	Halteclip	Clip sujeción
7	Wire ignition KD5 SD6,3 SD4	CABLE ALLUM KD5 SD6,3 SD4	Cavetto accensione KD5 SD6,3 SD4	Hoogspanningsleiding KD5 SD6,3 SD4	Cable de encendido KD5 SD6,3 SD4
8	Cable SAFe - Ignition everp	Conduite de raccordement SAFe-Allumage	Tubazione di collegamento SAFe-Accension	verbindingsleiding SAFe-Ontsteking	tubo de conexión SAFe-De encendido
9	Cable SAFe - MV1 everp	Conduite de raccordement SAFe-MV1	Tubazione di collegamento SAFe-MV1	verbindingsleiding SAFe-MV1	tubo de conexión SAFe-MV1
10	Cable SAFe - Power	cordon branchement réseau	cavo di rete	netkabel	línea de conexión a red
11	Cable connector flow/return	Conduite de raccordement départ/retour	Tubazione di collegamento mandata/ritorn	Verbind.leiding vertrek/retour voel	Cable de conexión sonda
12	Wire SAFe - RMx 990mm	CABLES DONNEES SAFe RMx 990mm	Cavo dati SAFe RMx 990mm	Datakabel SAFe RMx 990mm	Cable de datos SAFe RMx 990mm
13	Y-cable adaptor	Y-câble adaptateur	Y-Cavo Adattore	Y-kabel adapter	Y-cables adaptador
14	Wire SAFe - FK	Conduite de raccordement SAFe-FK	Tubazione di collegamento SAFe-FK	verbindingsleiding SAFe-FK	tubo de conexión SAFe-FK
15	Cable Ionisation K 125/230	câbles d'ionisation K 125/230	Cavo di ionizzazione K 125/230	ionisatiekabel K 125/230	conjunto cables de ionización K 125/230
16	Cable Y Fan Adaptor 50KW everp	Y-câble adaptateur 50KW	Y-Cavo Adattore 50KW	Y-kabel adapter 50KW	Y-cables adaptador 50KW
<b>9A</b>	<b>Element of construction</b>	<b>Groupe de construction</b>	<b>Gruppo di costruzione</b>	<b>Montagegroep</b>	<b>Grupo de construccion</b>
1	Housing upper part blue	Carter partie superieure bleu	Parte superiore involucro blu	Huis bovendeeel blauw	Carcasa superior para conex. Modulos
2	Screw M 3.5 x 12 (6x)	Vis M 3.5 x 12 (6x)	Vite M 3,5 x 12 (6x)	Schroef M 3,5 x 12 (6x)	Tornillo M 3,5 x 12 (6x)
3	Housing modul mounting MC40 blue	Plaque de jonction blanc	Supporto bianco	Drager wit	Soporte blanc
4	Connector PCB SFA S01 everp	Circuit imprimé SFA S01 everp	Circuito stampato SFA S01 everp	Printplaat SFA S01 everp	Placa electrónica SFA S01 everp
5	Fuse application 5x20 6,3AT 230V (10x)	Fusible arrière 5x20 6,3AT 230V (10x)	Fusibile posteriore 5x20 6,3AT 230V(10x)	Buismeltveilig. Achter 5x20 6,3AT 230V	Fusible 5x20 6,3AT 230V (10x)
6	Fuseholder cap	Support de fusible	Porta fusibile	Zekeringhouder	Soporte fusible
7	Mains supply cable inlet connector for	Cordon branchement reseau	Cavo di rete	Netaansluitleiding koudetest G135	Cable conexión red SAFe
8	Connector 4-pol 17B18 orange	Borne de raccordeme 4 poles 17B18 orange	Morsetto di collegamento 4-pol. 17B18	Aansluitklem 4-pol. 17B18 oranje	Borne de conexión 4- polos anaranjado
9	Connector 3-pole white	Borne de connexion 3- pôles blanc	Morsetto di collegamento 3-bipol. bianco	Aansluitklem 3-polig wit	Connector 3-pole white
10	Connecting terminal pluggable 3-pol	Borne de connexion 3- pôles jaune	Morsetto di collegamento 3-bipol. giallo	Afsluitklem 3- polig geel	Borne de conexión 3- polos amarillo
11	Connector 4-pole SH I violet	Borne de connexion 4- pôles SH I violet	Morsetto di collegame.4-bipol.SH I viol.	Aansluitklem 4-pol SH I violet	Borne de conexión 4- polos SH I violeta
12	Connector 3-pole PS grey	Borne de connexion 3- pôles ps gris	Morsetto di collegamento 3-pol.PS grigio	Aansluitklem 3-polig PS grijs	Connector 3-pole PS grey
13	Connector 3-pole PZ violett	Connecteur 3 poles violet	Morsetto di collegamento - pol.PZ violett	Aansluitklem 3-polig PZ violet	Connector 3-pole PZ violett

<b>Übersetzungsliste</b> <b>List of translations</b>		<b>Liste des traductions</b> <b>Traduzione delle descrizioni</b>		<b>Vertalinglijst</b> <b>Lista de traducciones</b>	
Pos	Description	Denomination	Descrizione	Benaming	Descripción
14	Connector 3-pole PH green	Borne de connexion 3- pôles PH vert	Morsetto di collegamento 3-pol. PH verde	Afsluitklem 3-polig PH groen	Connector 3-pole PH green
15	Connecting terminal 2-polig WA maygreen	Fiche verte 2 poles wa	Morsetto di collegamento2-bipol WA verde	Afsluitklem 2-polig WA groen	Borne de conexión 2-polos WA verde
16	Connector 2- pin blue	Borne de connexion 2- pol r5 bl everp	Morsetto di collegamento 2- bipolare blu	Aansluitconnector 2-polig blauw	Borne de conexión 2-polos azul
17	Connector 2-pole grey FW	Borne de connexion 2- pôles gris FW	Morsetto di collegame.2-bipol. grigio FW	Afsluitklem 2- polig grijs FW	Borne de conexión 2-polos grey FW
18	Connect. term. 2-polig red	Fiche rouge 2 poles	Morsetto di collegamento2- bipolare rosso	Afsluitklem 2-polig rood	Borne de conexión 2-polos rojo
19	Connector 2- pin orange RC	Borne de connexion 2- pôles orange RC	Morsetto di collegamento2- bip.arancione	Aansluitconnector 2- polig oranje RC	Borne de conexión 2-polos anaranjado RC
20	Connector 2-pole white	Borne de connexion 2-polos blanc	Morsetto di collegamento2-pol bianco	Aansluitklem 2-polig wit	Connector 2-pole white
22	Connecting cable 155mm	Câble 155mm	Cavo 155mm	Kabel 155mm	Cable de conexión 155mm
23	Circuit board MC40 + Cable harness V1	Circuit imp MC40 + Faisceau de câbles V1	Circuito stampato MC40 + Cablaggio V1	Printplaat MC40 + Kabelboom V1	Placa electr. MC40 + Mazo de cables V1
24	Housing strain relief control (10x)	Décharge de traction (10x)	Fermo antitrazione (10x)	Trekontlasting (10x)	Retenedor de cable (10x)
25	User interface MC40 S03 LCD white	Module de commande MC40 S03 LCD blanc	Controllo remoto MC40 S03 LCD bianco	Bedieningsunit MC40 S03 LCD wit	Unidad de mando MC40 S03 LCD blanco
26	Housing blind cover BC white	Couvercle BC blanc	Copertura BC	Afdekking BC wit	Recubrimiento BC blanco
27	Housing Visor f. control	capot	Coperchio	afdekkap	capota
<b>9B</b>	<b>Element of construction</b>	<b>Groupe de construction</b>	<b>Gruppo di costruzione</b>	<b>Montagegroep</b>	<b>Grupo de construccion</b>
1	Controller complete MC100+BC100 S21 blue	Controleur complet MC100+BC100 S21 bleu	Regolazione completa MC100+BC100 S21 blu	Regeling MC100+BC100 S21 blauw	Controlador completoMC100+BC100 S21 azul
2	Screw M 3.5 x 12 (6x)	Vis M 3.5 x 12 (6x)	Vite M 3,5 x 12 (6x)	Schroef M 3,5 x 12 (6x)	Tornillo M 3,5 x 12 (6x)
3	Housing upper part blue	Carter partie superieure bleu	Parte superiore involucro blu	Huis bovendeel blauw	Carcasa superior para conex. Modulos
4	Housing module carrier white	Module plaque de jonction blanc	Modulo Supporto bianco	Module drager wit	Módulo soporte blanco
5	Fuse application 5x20 6,3AT 230V (10x)	Fusible arrière 5x20 6,3AT 230V (10x)	Fusibile posteriore 5x20 6,3AT 230V(10x)	Buissmeltveilig. Achter 5x20 6,3AT 230V	Fusible 5x20 6,3AT 230V (10x)
6	Fuseholder cap	Support de fusible	Porta fusibile	Zekeringhouder	Soporte fusible
7	Connector 3-pole white	Borne de connexion 3- pôles blanc	Morsetto di collegamento 3- bipol. bianco	Aansluitklem 3-polig wit	Connector 3-pole white
8	Connector 3-pol. SF50 pink	Borne de raccordement 3-polos SF50 rose	Morsetto di collegamento 3-pol.SF50 rosa	Aansluitklem 3-polig SF50 roze	Borne de conexión 3-polos SF50 rosa
9	Wire Power HV 1270 Ferrit everp	faisceau de câbles Power HV 1270 Ferrit	Cablaggio Power HV 1270 Ferrit	kabelboom Power HV 1270 Ferrit	mazo de cables Power HV 1270 Ferrit
11	Connector 4-pol 17B18 orange	Borne de raccordeme 4 poles 17B18 orange	Morsetto di collegamento 4-pol. 17B18	Aansluitklem 4-pol. 17B18 oranje	Borne de conexión 4- polos anaranjado
12	Connecting terminal pluggable 3-pol	Borne de connexion 3- pôles jaune	Morsetto di collegamento 3- bipol. giallo	Afsluitklem 3- polig geel	Borne de conexión 3- polos amarillo
13	Connector 4-pole SH I violet	Borne de connexion 4- pôles SH I violet	Morsetto di collegame.4- bipol.SH I viol.	Aansluitklem 4-pol SH I violet	Borne de conexión 4- polos SH I violeta
14	Connector 3-pole PS grey	Borne de connexion 3- pôles ps gris	Morsetto di collegamento 3-pol.PS grigio	Aansluitklem 3-polig PS grijs	Connector 3-pole PS grey
15	Connector 3-pole PZ violett	Connecteur 3 poles violet	Morsetto di collegamento - pol.PZ violett	Aansluitklem 3-polig PZ violet	Connector 3-pole PZ violett
16	Connector 3-pole PH green	Borne de connexion 3- pôles PH vert	Morsetto di collegamento 3-pol. PH verde	Afsluitklem 3-polig PH groen	Connector 3-pole PH green
18	Connector 3-pol. AS red sparepart	Borne de raccordement 3-polos AS rouge	Morsetto di collegamento3- bipol.AS rosso	Aansluitklem 3-polig AS rood	Borne de conexión 3-polos AS rojo
19	Connecting terminal 2-polig WA maygreen	Fiche verte 2 poles wa	Morsetto di collegamento2-bipol WA verde	Afsluitklem 2-polig WA groen	Borne de conexión 2-polos WA verde

Übersetzungsliste List of translations		Liste des traductions Traduzione delle descrizioni		Vertalinglijst Lista de traducciones	
Pos	Description	Denomination	Descrizione	Benaming	Descripción
20	Connector 2- pin blue	Borne de connexion 2- pol r5 bl everp	Morsetto di collegamento 2- bipolare blu	Aansluitconnector 2-polig blauw	Borne de conexión 2-polos azul
21	Connector 2-pole grey FW	Borne de connexion 2- pôles gris FW	Morsetto di collegame.2-bipol. grigio FW	Afsluitklem 2- polig grijs FW	Borne de conexión 2-polos grey FW
22	Connect. term. 2-polig red	Fiche rouge 2 poles	Morsetto di collegamento2- bipolare rosso	Afsluitklem 2-polig rood	Borne de conexión 2-polos rojo
23	Connector 2- pin orange RC	Borne de connexion 2- pôles orange RC	Morsetto di collegamento2- bip.arancione	Aansluitconnector 2- polig oranje RC	Borne de conexión 2-polos anaranjado RC
24	Connector 2-pole white	Borne de connexion 2-polos blanc	Morsetto di collegamento2-pol bianco	Aansluitklem 2-polig wit	Connector 2-pole white
30	Housing strain relief control (10x)	Décharge de traction (10x)	Fermo antitrazione (10x)	Trekontlasting (10x)	Retenedor de cable (10x)
31	Printed circuit board MC100 S21	Circuit imprimé MC100 S21	Circuito stampato MC100 S21	Printplaat MC100 S21	Placa electrónica MC100 S21
33	Cable harness IP*S01	Faisceau de câbles IP*1 S01	Cablaggio IP*1 S01	Kabelboom IP*1 S01	Mazo de cables IP*1 S01
34	Connecting cable 155mm	Câble 155mm	Cavo 155mm	Kabel 155mm	Cable de conexión 155mm
35	Control_unit BC100 S08w BC100 cable blue	Tableau de commandeBC100+faisceau de câ.	Pannello di comando BC100+Cablaggio blu	Bedieningspaneel BC100+kabelboom blauw	Cuadro de maniobra BC100+mazo de cables
36	Housing blind cover BC white	Couvercle BC blanc	Copertura BC	Afdekking BC wit	Recubrimiento BC blanco
37	Housing Visor f. control	capot	Coperchio	afdekkap	capota
40	Outdoor temperature sensor	Sonde de température extérieure	Sonda temperatua esterna	Buitentemperatuursensor	Sensor de temperatura exterior
41	Temperature sensor RD 6,0 10kΩ 3000mm	Sonde de température RD6,0 10kOHM 3000mm	Sonda di temperatua RD 6,0 10kΩ 3000mm	Temperatuursensor RD 6,0 10kΩ 3000mm	Sensor de temperatura RD 6,0 10kΩ 3000mm
50	MX300	MX300	MX300	MX300	
51	Key wallsocket & cable set	Support mural set	Supporto a parete set	Muurbeugel set	Soporte de pared set
52	Basic kit connect key	Set de base du module sans fil	Set base connessione modulo wireless	Basis wireless module	Módulo conexión adaptado inalámbrico
	Screw M 3.5 x 12 (6x)	Vis M 3.5 x 12 (6x)	Vite M 3,5 x 12 (6x)	Schroef M 3,5 x 12 (6x)	Tornillo M 3,5 x 12 (6x)
	LAN-Cable RJ45 Cat.5 2000	LAN-câble 2000	LAN-Cavo 2000	LAN-kabel 2000	LAN-cables 2000

Gerätetypen Types of appliances		Types de chaudières Tipo apparecchi	Toesteltypen Tipos de aplicaciones
Gerät Appliance Chaudière Apparecchio Toestel Aparato		Land Country Pays Paese Land Paese	Bemerkungen Remarks Remarques Osservazioni Opmerkingen Observaciones
GB212-30 G20	7 736 616 403	AT,BE,CH,CZ,DE,HU,IT,LU,SK	
GB212-50 G20	7 736 616 401	AT,BE,CH,CZ,DE,IT,LU	
GB212-40 G20	8 718 581 564	AT,BE,CH,CZ,DE,LU	
GB212-15 G20	8 718 581 561	AT,CH,CZ,DE,LU	
GB212-22 G20	8 718 581 562	AT,CH,CZ,DE,LU	
GB212-15 G25	8 718 582 825	AT,DE,LU	
GB212-22 G25	8 718 582 826	AT,DE,LU	
GB212-30, G20	8 718 581 563	AT,DE,LU	
GB212-30, G25	8 718 582 827	AT,DE,LU	
GB212-40 G25	8 718 582 828	AT,DE,LU	
GB212-15 G20	7 736 615 973	BE	
GB212-15/5 G20 BE	7 736 600 273	BE	
GB212-22 G20	7 736 615 974	BE	
GB212-22/6 G20 BE	7 736 600 274	BE	
GB212-30 G20	7 736 615 975	BE	
GB212-30/6 G20 BE	7 736 600 275	BE	
GB212-40 G20	7 736 615 976	BE	
GB212-40/10 G20 BE	7 736 600 276	BE	
GB212-50/10 G20 BE	7 736 600 277	BE	
GB212-15 G20	7 736 615 977	CH	
GB212-22 G20	7 736 615 978	CH	
GB212-30 G20	7 736 615 979	CH	
GB212-40 G20	7 736 615 980	CH	
GB212-15/5 G20 IP	8 718 591 854	DE,LU	
GB212-15/5 G25 IP	8 718 591 856	DE,LU	
GB212-22/6 G20 IP	8 718 591 855	DE,LU	
GB212-22/6 G25 IP	8 718 591 857	DE,LU	
GB212-30 G25	7 736 616 404	DE,LU	
GB212-50 G25	7 736 616 402	DE,LU	
GB212-15 G20	7 736 615 993	HU	
GB212-22 G20	7 736 615 994	HU	
GB212-30 G20	7 736 615 995	HU	
GB212-40 G20	7 736 615 996	HU	

Gerätetypen Types of appliances		Types de chaudières Tipo apparecchi		Toesteltypen Tipos de aplicaciones	
Gerät Appliance Chaudière Apparecchio Toestel Aparato		Land Country Pays Paese Land Paese		Bemerkungen Remarks Remarques Osservazioni Opmerkingen Observaciones	
GB212-15 G20	7 736 615 981	IT			
GB212-22 G20	7 736 615 982	IT			
GB212-30 G20	7 736 615 983	IT			
GB212-40 G20	7 736 615 984	IT			
GB212-15 G20	7 736 615 985	PL			
GB212-22 G20	7 736 615 986	PL			
GB212-30 G20	7 736 615 987	PL			
GB212-40 G20	7 736 615 988	PL			
GB212-15 G20	7 736 615 989	SK			
GB212-22 G20	7 736 615 990	SK			
GB212-30 G20	7 736 615 991	SK			
GB212-40 G20	7 736 615 992	SK			



Bosch Thermotechnik GmbH  
Sophienstr. 30-32  
D-35576 Wetzlar / Germany

**Buderus**